

Instruction Manual

DF3/FF3 SERIES

High Voltage Power Supply

MODEL :
SERIAL# :
DATE :

**SPELLMAN
HIGH VOLTAGE ELECTRONICS
CORPORATION**

475 Wireless Blvd.
Hauppauge, New York, 11788

+1(631) 630-3000*FAX: +1(631) 435-1620*
E-mail: sales@spellmanhv.com
Website: www.spellmanhv.com



- **IDEAL FOR COMMON XRD & XRF X-RAY TUBES**
- **COMPACT SIZE, 5 1/4" (3U) HIGH CHASSIS**
- **SOLID ENCAPSULATION INSURES MAINTENANCE-FREE OPERATION**
- **AUTO RAMP OF THE HV EMISSION CURRENT TO PRESET VALUES**
- **OEM CUSTOMIZATION AVAILABLE**

www.spellmanhv.com/manuals/DFFF

Spellman's DF/FF Series of X-ray Generators feature our new inverter design which incorporates IGBTs for power switching and provides new levels of reliability. In addition, re-engineering of the DF/FF's internal filament power supply eliminates audio noise at normal operating levels by operating at a higher frequency. The DF/FF's utilize a sine wave current source, produced by phase shifting series resonant circuits at switching frequencies greater than 20kHz to generate high voltage dc. This technique eliminates undesirable electromagnetic radiation normally associated with switching and power control regulators. The high efficiency of these units allows for air cooling in a 5 1/4" (3U) high chassis.

TYPICAL APPLICATIONS

X-ray Diffraction (XRD)
X-ray Fluorescence (XRF)

ADDITIONAL FEATURES

Water Flow Switch:

A 24Vdc signal is available on the rear panel to turn on the cooling water to the X-ray tube. This signal can be enabled either when control power is on or when the high voltage is turned on. (Customer must specify).

Fail Safe Interlock:

A 24Vdc signal is available on the rear panel to energize an external X-ray on lamp. This signal is energized when the high voltage is turned on. High voltage will not enable if this circuit is open. (A 220Vac signal is optional).

Preheat and Ramp:

Automatic preheat and ramp control circuits are provided which ramp the kV and mA slowly to set levels. kV ramps in approximately 10 seconds while mA ramps in approximately 20 seconds.

Output Connector:

75kV, 3 conductor Federal Standard X-ray connector. -60kV is connected to terminal "C". Terminals "S" and "L" are jumped together. The filament output is connected between terminals "C" and "S". Other configurations are optional. (On the FF3, all output connections S, L, & C are connected together).

Remote Signal Connector:

Remote interface is available via a 50 pin mini D connector. Extensive remote programming and monitoring is provided.

OPTIONS

RS232	RS232 Interface
220FSI	220Vac Fail Safe Interlock
208-3P	208Vac Three Phase Input

SPECIFICATIONS

Input Voltage:

220Vac \pm 10%, 50 or 60 Hz, single phase
(three phase optional).

Output Voltage:

DF3: 0 to 60kV negative polarity.
FF3: 0 to 60kV positive polarity.
Other output voltages are available.

Output Current:

DF3: 0 to 80mA.
FF3: 0 to 100mA.
Other output currents are available.

Maximum Output Power:

3kW (4kW optional).

Output Voltage Regulation:

Load: 0.005% of rated output for full load change.
Line: 0.005% of rated output over specified input range.
Temperature Coefficient: 50 ppm/ $^{\circ}$ C (20 ppm/ $^{\circ}$ C optional).
Long Term Stability: 0.01%/8 hours.

Emission Current Regulation:

Load: 0.01% of rated output for a 10 to 60kV change.
Line: 0.005% of rated output over specified inputs.
Temperature Coefficient: 50 ppm/ $^{\circ}$ C
Long Term Stability: 0.01%/8 hours.

Ripple:

0.03% rms <1kHz, 0.75% rms above 1kHz.

Environmental:

Temperature Range:
Operating: 0 $^{\circ}$ C to 40 $^{\circ}$ C
Storage: -20 $^{\circ}$ C to 85 $^{\circ}$ C
Humidity:
10% to 90%, non-condensing.

Filament Voltage:

12Vac (dc filament optional).

Filament Current:

5A (up to 12A max available).

Dimensions:

5 1/4" (3U) H x 19" W x 22" D
(13.3cm x 48.3cm x 55.9cm).

Weight:

90 lbs (40kg).

Regulatory Approvals:

Compliant to 2004/108/EC, The EMC Directive and 2006/95/EC, The Low Voltage Directive.

DF/FF MINI D CONNECTOR 50 PIN

JB1	SIGNAL
1	+5Vdc (or connect to pin-11)
2	Control Power On
3	Intlk
4	X-ray On
5	X-ray Off
6	Spare
7	Spare
8	Reset
9	Rmt/Lcl
10	24V Switched
11	+5Vcch
12	X-ray On Status
13	Overvoltage
14	kV Min
15	Overpower
16	Filament Current Limit
17	mA Current Limit
18	LCL Status
19	Power Supply Fault
20	Gnd
21	Spare
22	(DF) Remote X-ray On
23	(DF) Remote X-ray On Ret
24	Spare
25	Gnd
26	kV Ref
27	kV Com
28	mA Ref
29	mA Com
30	Spare
31	Spare
32	Spare
33	Pwr. Limit (OL Ref)
34	Pwr. Limit Com (OL Com)
35	Filament Current Limit
36	Filament Current Limit Com
37	Spare
38	kV Monitor
39	mA Monitor
40	Spare
41	Spare
42	kV Ref Mon
43	mA Ref Mon
44	Spare
45	Spare
46	Filament Monitor
47	Mon Common
48	Spare
49	Gnd
50	Spare



DIMENSIONS: in.[mm]

FRONT VIEW

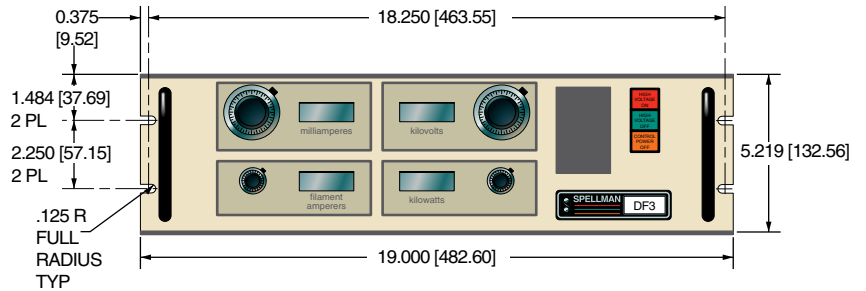

TOP VIEW

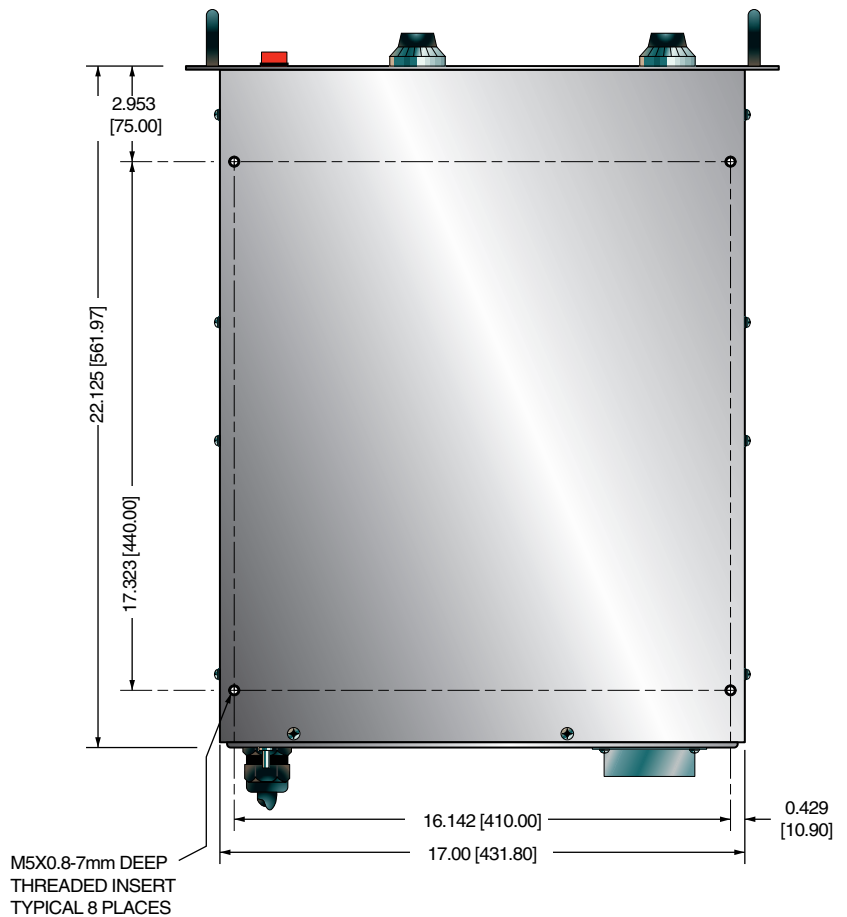

BACK VIEW

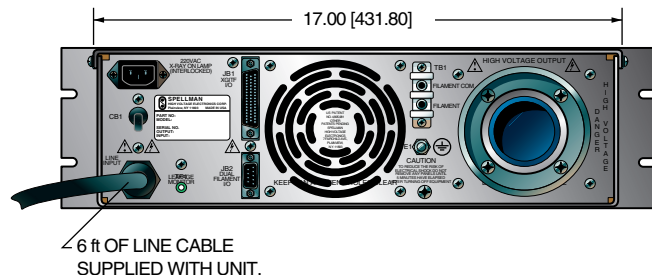

USA +1-631-630-3000
 UK +44 (0)1798 877000
 JAPAN +81 (0)48-447-6500
 CHINA +86 (0)512-67630010

FAX: +1-631-435-1620
 FAX: +44 (0)1798 872479
 FAX: +81 (0)48-447-6501
 FAX: +86 (0)512-67630030

e-mail: sales@spellmanhv.com
 www.spellmanhv.com

128001-001 REV.F

Spellman High Voltage is an ISO 9001:2000 and ISO 14001:2004 registered company

IMPORTANT SAFETY PRECAUTIONS

SAFETY

THIS POWER SUPPLY GENERATES VOLTAGES THAT ARE DANGEROUS AND MAY BE FATAL.
OBSERVE EXTREME CAUTION WHEN WORKING WITH THIS EQUIPMENT.

High voltage power supplies must always be grounded.

Do not touch connections unless the equipment is off and the Capacitance of both the load and power supply is discharged.

Allow five minutes for discharge of internal capacitance of the power supply.

Do not ground yourself or work under wet or damp conditions.

SERVICING SAFETY

Maintenance may require removing the instrument cover with the power on.

Servicing should be done by qualified personnel aware of the electrical hazards.

WARNING note in the text call attention to hazards in operation of these units that could lead to possible injury or death.

CAUTION notes in the text indicate procedures to be followed to avoid possible damage to equipment.

Copyright © 2000, Spellman High Voltage Electronics Corporation. All Rights Reserved.
This information contained in this publication is derived in part from proprietary and patent data. This information has been prepared for the express purpose of assisting operating and maintenance personnel in the efficient use of the model described herein, and publication of this information does not convey any right to reproduce it or to use it for any purpose other than in connection with installation, operation, and maintenance of the equipment described.

WICHTIGE SICHERHEITSHINWEISE

SICHERHEIT

DIESES HOCHSPANNUNGSNETZTEIL ERZEUGT LEBENSGEFÄHRLICHE HOCHSPANNUNG.
SEIN SIE SEHR VORSICHTIG BEI DER ARBEIT MIT DIESEM GERÄT.

Das Hochspannungsnetzteil muß immer geerdet sein.

Berühren Sie die Stecker des Netzteiles nur, wenn das Gerät ausgeschaltet ist und die elektrischen Kapazitäten des Netzteiles und der angeschlossenen Last entladen sind.

Die internen Kapazitäten des Hochspannungsnetzteiles benötigen ca. 5 Minuten, um sich zu entladen.

Erden Sie sich nicht, und arbeiten Sie nicht in feuchter oder nasser Umgebung.

SERVICESICHERHEIT

Notwendige Reparaturen können es erforderlich machen, den Gehäusedeckel während des Betriebes zu entfernen.

Reparaturen dürfen nur von qualifiziertem, eingewiesenem Personal ausgeführt werden.

“WARNING” im folgenden Text weist auf gefährliche Operationen hin, die zu Verletzungen oder zum Tod führen können.

“CAUTION” im folgenden Text weist auf Prozeduren hin, die genauestens befolgt werden müssen, um eventuelle Beschädigungen des Gerätes zu vermeiden.

PRECAUTIONS IMPORTANTES POUR VOTRE SECURITE

CONSIGNES DE SÉCURITÉ

CETTE ALIMENTATION GÉNÈRE DES TENSIONS QUI SONT DANGEUREUSES ET PEUVENT ÊTRE FATALES.
SOYEZ EXTRÊMEMENT VIGILANTS LORSQUE VOUS UTILISEZ CET ÉQUIPEMENT.

Les alimentations haute tension doivent toujours être mises à la masse.

Ne touchez pas les connectiques sans que l'équipement soit éteint et que la capacité à la fois de la charge et de l'alimentation soient déchargées.

Prévoyez 5 minutes pour la décharge de la capacité interne de l'alimentation.

Ne vous mettez pas à la masse, ou ne travaillez pas sous conditions mouillées ou humides.

CONSIGNES DE SÉCURITÉ EN CAS DE REPARATION

La maintenance peut nécessiter l'enlèvement du couvercle lorsque l'alimentation est encore allumée.

Les réparations doivent être effectuées par une personne qualifiée et connaissant les risques électriques.

Dans le manuel, les notes marquées « **WARNING** » attire l'attention sur les risques lors de la manipulation de ces équipements, qui peuvent entraîner de possibles blessures voire la mort.

Dans le manuel, les notes marquées « **CAUTION** » indiquent les procédures qui doivent être suivies afin d'éviter d'éventuels dommages sur l'équipement.

IMPORTANTI PRECAUZIONI DI SICUREZZA

SICUREZZA

QUESTO ALIMENTATORE GENERA TENSIONI CHE SONO PERICOLOSE E POTREBBERO ESSERE MORTALI.
PONI ESTREMA CAUTELA QUANDO OPERI CON QUESTO APPARECCHIO.

- Gli alimentatori ad alta tensione devono sempre essere collegati ad un impianto di terra.
- Non toccare le connessioni a meno che l'apparecchio sia stato spento e la capacità interna del carico e dell'alimentatore stesso siano scariche.
- Attendere cinque minuti per permettere la scarica della capacità interna dell'alimentatore ad alta tensione.
- Non mettere a terra il proprio corpo oppure operare in ambienti bagnati o saturi d'umidità.

SICUREZZA NELLA MANUTENZIONE.

- Manutenzione potrebbe essere richiesta, rimuovendo la copertura con apparecchio acceso.
- La manutenzione deve essere svolta da personale qualificato, coscio dei rischi elettrici.
- Attenzione alle **AVVERTENZE** contenute nel manuale, che richiamano all'attenzione ai rischi quando si opera con tali unità e che potrebbero causare possibili ferite o morte.
- Le note di **CAUTELA** contenute nel manuale, indicano le procedure da seguire per evitare possibili danni all'apparecchio.

TABLE OF CONTENTS

1	INTRODUCTION	1
1.1	DESCRIPTION OF THE DF3/FF3 SERIES	1
1.2	DF3 SPECIFICATIONS	1
1.3	FF3 SPECIFICATIONS.....	1
1.4	STANDARD FEATURES	2
1.5	OPTIONS	3
1.6	INTERPRETING THE MODEL NUMBER	4
2	INSPECTION & INSTALLATION.....	5
2.1	INITIAL INSPECTION	5
2.2	MECHANICAL INSTALLATION	5
3	OPERATING INSTRUCTIONS.....	7
3.1	OPERATION	7
3.2	STANDARD FEATURES:.....	11
4	PRINCIPLES OF OPERATION.....	18
4.1	CHASSIS	19
4.2	LINE RECTIFICATION AND FILTERING.....	19
4.3	INVERTER.....	19
4.4	HIGH VOLTAGE TRANSFORMER.....	19
4.5	HIGH VOLTAGE ASSEMBLY	20
4.6	SYSTEM CONTROL PWB.....	20
4.7	FRONT PANEL ASSEMBLY	20
4.8	REAR PANEL INTERFACE PWB.....	20
4.9	FILAMENT POWER PWB	21
4.10	OPTIONS.....	21
5	OPTIONS	22
5.1	208V AC THREE PHASE INPUT	22
5.2	HIGH STABILITY	22
5.3	220VAC FAIL SAFE CIRCUIT	22
5.4	12VDC FAIL SAFE CIRCUIT	22
5.5	24VDC WATER FLOW SIGNAL	22
5.6	220VAC WATER FLOW SIGNAL	22
5.7	DUAL FILAMENT SUPPLY	22
5.8	4kV OUTPUT	22
5.9	ELAPSED TIME METER	22
5.10	LARGE-COMMON	22
5.11	NON-STANDARD SLOW START	22
5.12	SLIDES	22
5.13	CUSTOM DESIGNED MODELS	22
6	MAINTENANCE.....	23
6.1	PERIODIC SERVICING	23
6.2	PERFORMANCE TEST	23
6.3	HIGH VOLTAGE DIVIDERS	23
7	REPLACEMENT PARTS	24
7.1	REPLACEMENT PARTS	24
7.2	CORRESPONDENCE AND ORDERING SPARE PARTS	24
8	FACTORY SERVICE.....	25
8.1	WARRANTY REPAIRS	25
8.2	FACTORY SERVICE PROCEDURES	25
8.3	ORDERING OPTIONS AND MODIFICATIONS	25
8.3	SHIPPING INSTRUCTIONS	25

LIST OF ILLUSTRATIONS

TABLE 1.1	OPTIONS	4
FIGURE 2.1	DIMENSIONS	6
FIGURE 3.1A	DF3/FF3 FRONT PANEL LAYOUT	8
FIGURE 3.1B	DF3 TYPICAL OPERATING SETUP	9
FIGURE 3.1C	FF3 TYPICAL OPERATING SETUP	9
FIGURE 3.1D	WIRING DIAGRAM FOR JB1, LOCAL CONTROL	10
FIGURE 3.2	REMOTE CONTROL	12
TABLE 3.1	LOCAL/REMOTE DIP SWITCH SETTINGS	12
FIGURE 3.3	REMOTE MONITOR	13
FIGURE 3.4	REMOTE ON/OFF CONTROL	14
FIGURE 3.5	REMOTE STATUS INDICATOR.....	15
FIGURE 3.6A	REMOTE FAIL SAFE INDICATORS 24V DC	16
FIGURE 3.6B	REMOTE FAIL SAFE INDICATORS 220V DC.....	17
FIGURE 3.7D	REMOTE WATER SELENOID CONTROL	17
TABLE 4.1	DF3/FF3 ASSEMBLIES	19

APPENDIX.....

SPECIFICATION CONTROL DRAWING (NON-STANDARD UNIT ONLY)
SCHEMATICS

1 INTRODUCTION

1.1 DESCRIPTION OF THE DF3/FF3 SERIES

The DF3/FF3 series of high voltage power supplies represent a radically new advanced approach to X-ray generator power requirements. These power supplies provide all of the power, control, and support functions required for practically all X-ray diffraction (XRD) or X-ray fluorescence (XRF) applications. The DF3/FF3 series provide high voltage, high current outputs with very low ripple. Extremely stable voltage and current outputs result in significant performance improvements over previously available technology. Low output ripple provides higher intensity levels, with no increase in tube loading.

All of these advancements are possible only by Spellman's long history in X-ray power systems. This series of power supplies utilizes extremely advanced quasi-resonant PWM conversion techniques, along with sophisticated digital technology.

The DF3 series is specifically designed for XRD X-ray tube applications. The high voltage is a negative polarity, and the filament circuits are referenced to the cathode high voltage potential, (floating filament). The FF3 series is specifically designed for XRF X-ray tube applications. The high voltage is a positive polarity, and the filament circuits are referenced to cathode ground potential, (grounded filament).

The X-ray tube voltage, tube emission current, tube filament current limit, and maximum tube power, are all continuously adjustable front panel or remote controls.

The power supplies operate from a variety of line voltages and are fan-cooled, requiring no water-cooling. Custom designed units for single use or OEM applications are available.

1.2 DF3 SPECIFICATIONS

Input Voltage: 198-242Vac 50 or 60 Hz, single phase (three phase optional).

Output Voltage: 0-60kV negative polarity.

Output Current: 0-80mA.

Voltage Regulations:

Load regulation: 0.005% of rated output for a full load change.

Line Regulation: 0.005% of rated output over specified input range.

Temperature Coefficient: 50 ppm/°C (20 ppm/°C optional).

Long term Stability: 0.01% / 8 hours.

Current Regulation:

Load regulation: 0.01% of rated output for a 10-60kV change.

Line regulation: 0.005% of rated output over specified input range.

Temperature Coefficient: 50 ppm/C

Long term Stability: 0.01% / 8 hours.

Ripple: 0.03% below 1kHz, 0.75% rms above 1kHz.

Filament Voltage: 14Vac (dc filament optional).

Filament Current: 5A (up to 12A max available).

Size: 5 1/4" (13.26cm)H x 19" (48.26cm)W x 22" (55.88cm)D.

1.3 FF3 SPECIFICATIONS

Input Voltage: 198-242Vac 50 or 60 Hz, single phase (three phase optional).

Output Voltage: 0-60kV positive polarity.

Output Current: 0-100mA.

Voltage Regulations:

Load regulation: 0.005% of rated output for a full load change.

Line Regulation: 0.005% of rated output over specified input range.

Temperature Coefficient: 50 ppm/°C (20 ppm/°C optional).

Long term Stability: 0.01% / 8 hours.

Current Regulation:

Load regulation: 0.01% of rated output for a 10-60kV change.

Line regulation: 0.005% of rated output over specified input range.

Temperature Coefficient: 50 ppm/C

Long term Stability: 0.01% / 8 hours.

Ripple: 0.03% below 1kHz, 0.75% rms above 1kHz.

Filament Voltage: 14Vac (dc filament optional).

Filament Current: 12A ac.

Size: 5 ¼" (13.26cm)H x 19" (48.26cm)W x 22" (55.88cm)D.

1.4 STANDARD FEATURES

The DF3/FF3 series incorporates extensive standard features designed to optimize user control and safety.

KV AND MA/FILAMENT CURRENT RAMP CIRCUITS: This feature provides for a gradual rise for kV, mA, and filament current. This feature is designed to limit voltage shock and filament shock to the X-ray tube. The kV ramp rate is approximately 10 seconds. The filament current is slowly increased until the desired mA level is achieved. This time is typically 20 seconds for full mA output. These ramp conditions are started at the initial X-RAY ON control signal or when the kV control, (front panel potentiometer or remote programming), drops below the kV MIN level. The kV MIN level is typically set at 8kV. The kV MIN level is adjustable by an internal resistor valve. Other kV MIN levels can be accommodated. Consult Spellman Engineering for further information.

FAIL-SAFE, DUAL INDICATOR LAMPS:

The X-ray on lamp utilizes a sensing circuitry for detecting proper operation of the lamp for the indicator. If the X-ray on lamp is not functioning, the power supply will not generate high voltage. If the X-ray on lamp is depressed and the indicators do not illuminate, the lamps are defective and should be replaced in order to generate high voltage. Control power and X-ray off lamps are also dual type lamps for added reliability.

INTERNAL FAULT PROTECTION AND DIAGNOSTICS:

The DF3/FF3 series continually monitors internal circuits critical to the proper operation of the power supply and X-ray tube. The diagnostic circuits utilize sophisticated Programmable Logic Devices (PLD's). The diagnostic programming is a software based, decision-making technology. Flexible software provides very sophisticated decision-making capabilities within the power supply. Also, a variety of user configurations can be achieved by custom software written by Spellman Engineering. If a specific fault condition or diagnostic is required, consult Spellman High Voltage Engineering Department.

1.4.1 REMOTE OPERATING FEATURES

REMOTE PROGRAMMING: Allows remote adjustment of the output voltage, output current, filament current limit, and maximum tube power via an external voltage source.

REMOTE MONITOR: Allows remote monitoring of the output voltage and output current.

REMOTE X-RAY ON/OFF CONTROL:

Allows remote control of X-ray ON and X-ray OFF functions. Signals are also provided for remote indication of X-ray ON status. This can be used for a variety of water control or remote lamp functions.

REMOTE POWER ON: Allows remote control of Control Power ON/OFF function. This feature also allows remote reset of the power supply in case of a fault shutdown.

EXTERNAL INTERLOCK: Interlock connections are provided for a variety of water flow and safety functions. The unit will not operate unless the interlock is closed. Opening the interlock circuit will cause the unit to shut off.

REMOTE STATUS SIGNALS: A variety of power supply status signals are available on the remote interface. These signals are open collector type. Over current, over voltage, filament limit, overpower, and power supply fault status signals are available from the remote interface. Other signals can be supplied as required.

REMOTE FAIL-SAFE INDICATOR LAMP: A remote signal is available for connection to an external X-ray ON indicator lamp. This circuit senses proper operation of the external lamp and will shut down high voltage if the lamp is open. 12V-24Vdc or 220Vac lamps can be accommodated. 24Vdc is standard, other voltages may be specified when ordering.

REMOTE WATER SOLENOID CONTROL SIGNAL: A signal is provided for energizing a remote water solenoid for X-ray tube water flow requirements. This signal can be provided when the control power is energized or when X-ray ON is energized. 24Vdc energized with X-ray ON is standard, 220Vac switched is also provided. See 1.5 for optional configurations.

DUAL FILAMENT SUPPLY INTERFACE: An optional dual filament power supply is available. This chassis interfaces to the FF3 power supply. Consult Spellman's Sales Department for details.

1.4.2 SYSTEM STATUS AND FAULT DIAGNOSTIC DISPLAY

LED front panel indicators are provided to give the user indication of system operation and fault conditions. If a fault occurs, the power supply will shut down. To reset, toggle the CONTROL POWER ON switch, or use the reset function .

INTERLOCK CLOSED: Indicates the EXTERNAL INTERLOCK connections are in the closed position.

INTERLOCK OPEN: Indicates the EXTERNAL INTERLOCK connections are in the open position.

OVER VOLTAGE: Indicates the over voltage protection circuitry has caused the power

supply to turn off. Over voltage is internally set to 105%-110% of rated output voltage.

OVER CURRENT: Indicates the output current has exceeded 110% of rated output current. The over current level is internally set.

OVER POWER: indicates the output power has exceeded the front panel or remote programmed power trip level.

ARC: Indicates that a tube arc has occurred.

KV RGLT ERROR: Indicates that the high voltage regulation circuit cannot maintain voltage regulation. This may occur if the input voltage is too low.

MA RGLT ERROR: Indicates that the tube emission current regulation circuit cannot maintain current regulation. This may occur when tube filament problems exist.

FILAMENT CURRENT LIMIT: Indicates that filament current has exceeded the programmed filament current limit trip level.

KV MIN: Indicates the minimum KV level is not being programmed. This indicator will illuminate for approximately 10 seconds before shut down. This provides protection of the tube filament. The KV min circuitry also resets the KV and MA/filament ramp circuits. When the voltage is programmed higher than the kV min level, the outputs will begin the ramp cycle.

LEAKAGE LIMIT/TEMP: On the FF3 power supply, a tube leakage current detection circuit is provided. Shut down will occur if leakage current exceeds 10mA. A test point on the rear panel is also provided for test purposes.

OPEN FILAMENT: Indicates the X-ray tube filament or connections to the filament are open.

1.5 OPTIONS:

The options available are listed in Table 1.1. See Section 5 for more information on these options along with operating and set-up instructions. With few exceptions, these options can be retrofitted to your power supply at the factory in a short time. For price and retrofit arrangements, contact the Spellman Sales Department.

1.6 INTERPRETING THE MODEL NUMBER

The model number of the power supply describes its capabilities. After the series name is:

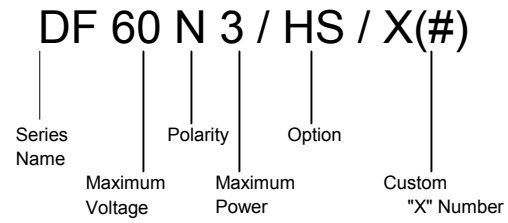

OPTION CODE	OPTION
3 PH	208Vac, ±10%, 3 phase, 50/60Hz input
HS	20ppm Temperature Coefficient (voltage and current)
FSI (220V)	Remote Fail-Safe circuit operating at 220Vac (replaces WFS 220V standard circuit)
FSI (12VDC)	Remote Fail-Safe circuit operating at 12Vdc (24Vdc standard)
WFS (24V/PO)	24Vdc water flow signal switched with power ON (switched with X-Ray ON is standard)
WFS (220V/PO)	220V ac water flow signal switch with power ON (switched with X-Ray ON standard) *Not available with FSI (220V)
DFS	Dual Filament supply (FF3 Only)
4kW	4kW maximum output power
ETM	Elapsed time meter – displays cumulative hours of X-Ray ON
LC	LC jumped together on X-Ray output connector (LS jumped is standard)
SL	Mounting Slides
SS(X)	Non-standard slow start (this should go out)

Table 1.1

2 INSPECTION & INSTALLATION

Initial inspection and preliminary checkout procedures are recommended. For safe operation, please follow the step-by-step procedures described in Chapter 3, Operating Instructions.

2.1 INITIAL INSPECTION

Inspect the package exterior for evidence of damage due to handling in transit. Notify the carrier and Spellman immediately if damage is evident. Do not destroy or remove any of the packing material used in a damaged shipment.

After unpacking, inspect the panel and chassis for visible damage.

Fill out and mail the Warranty Registration card accompanying the unit. Standard Spellman

DF3/FF3 high voltage power supplies and components are covered by warranty. Custom and special order models (with an X suffix in the model number) are also covered by warranty.

2.2 MECHANICAL INSTALLATION

Units in the DF3/FF3 series have front panel holes for standard EIA rack mounting. The rack must allow rear access for cable connections. Units are fully enclosed and are suitable for bench or tabletop operation. Standard unit dimensions are shown in Figure 2.1. It is strongly recommended to support the chassis by guides or slides. Slides are available for ease of servicing of the internal assemblies (SL option).

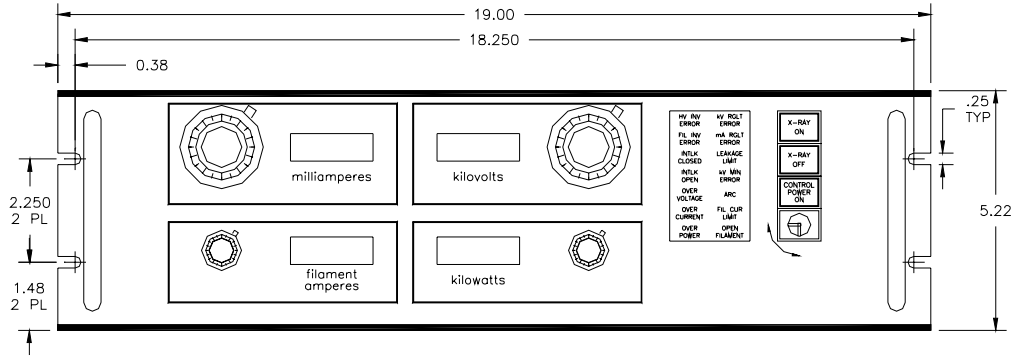

FRONT PANEL

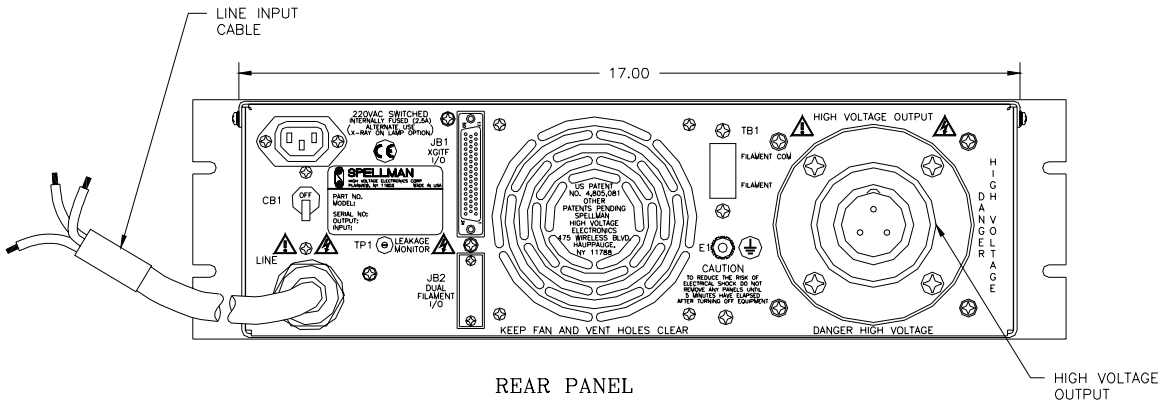
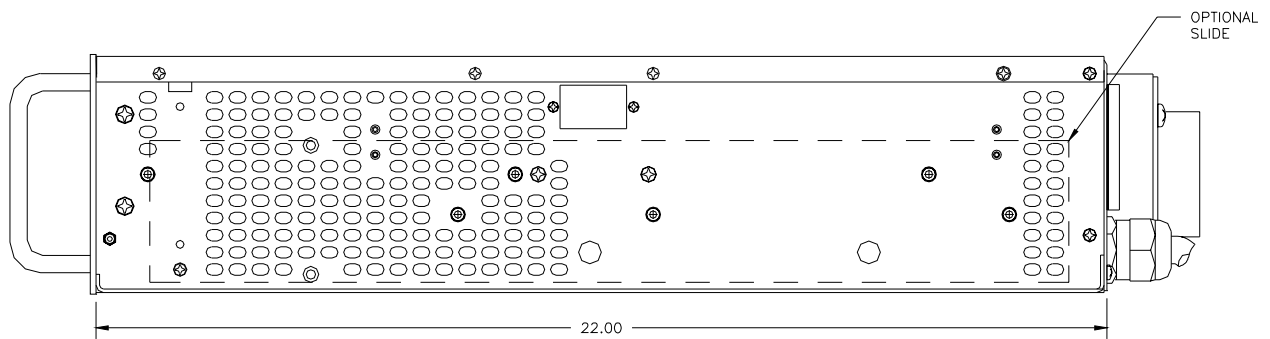

REAR PANEL

Figure 2.1 DF3/FF3 DIMENSIONS

3 OPERATING INSTRUCTIONS

3.1 OPERATION

WARNING

THIS EQUIPMENT GENERATES DANGEROUS VOLTAGES THAT MAY BE FATAL. PROPER GROUNDING OF ALL HIGH VOLTAGE EQUIPMENT IS ESSENTIAL.

IMPORTANT:

Before connecting the power supply to the AC line, follow this step-by-step procedure.

Do not connect the power supply to the AC line until Step H is reached.

Failure to follow these procedures may void the warranty.

A) Insure that the CONTROL POWER ON switch on your remote interface fixture is in the OFF (out) position.

B) Check the input voltage rating on the nameplate of the supply and make certain that this is the rating of the power source to be connected. DF3/FF3 units operate on 220VAC single phase, unless ordered with a different input voltage.

C) Proper Grounding Technique: The chassis of the high voltage power supply must be grounded to the local earth ground and also to the tube housing ground. See Figure 3.1A, 3.1B and 3.1C for typical operating setup.

A three-wire cable is provided for connecting to the AC supply. The Green wire is for chassis safety ground connection.

D) Connect the X-ray cable to the X-ray tube housing.

E) Connect the X-ray cable to the power supply. Insure the connector and housing is clean. Generally vacuum grease or oil is not required but can be used if desired. Tighten the cable collar to the connector housing.

F) Options Note: See Section 5 for hook up and operating instructions for the options on your unit. Custom models may also require set-up changes.

G) For initial turn on, set the kilovolt control fully counter clockwise to the zero position.

H) The input power cable may now be connected to the AC power source.

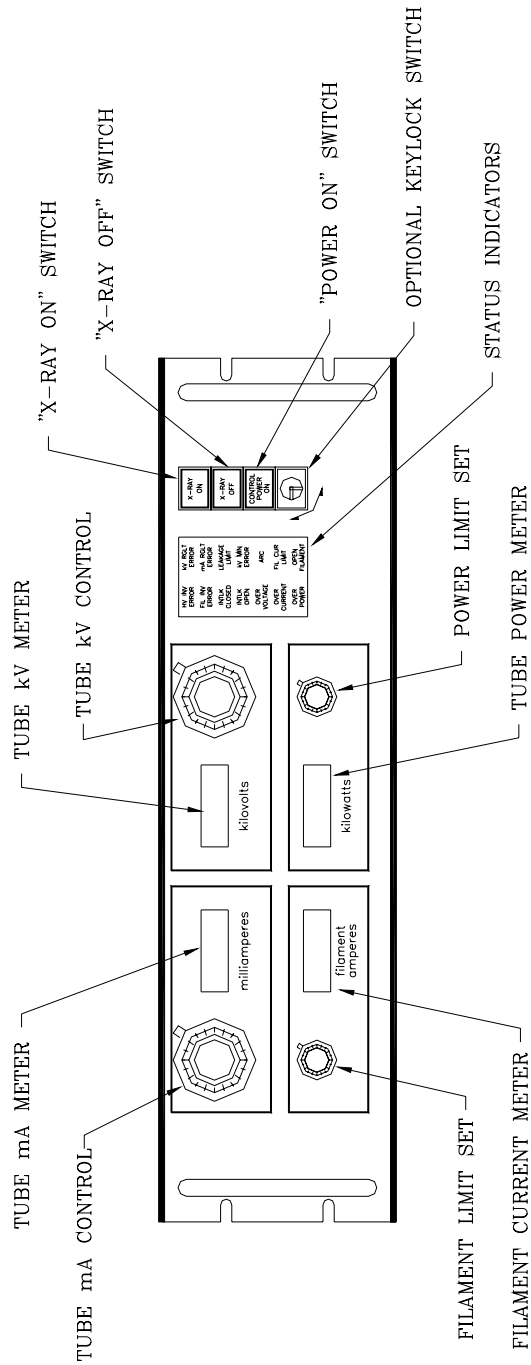

FIG. 3.1A DF3/FF3 FRONT PANEL LAYOUT

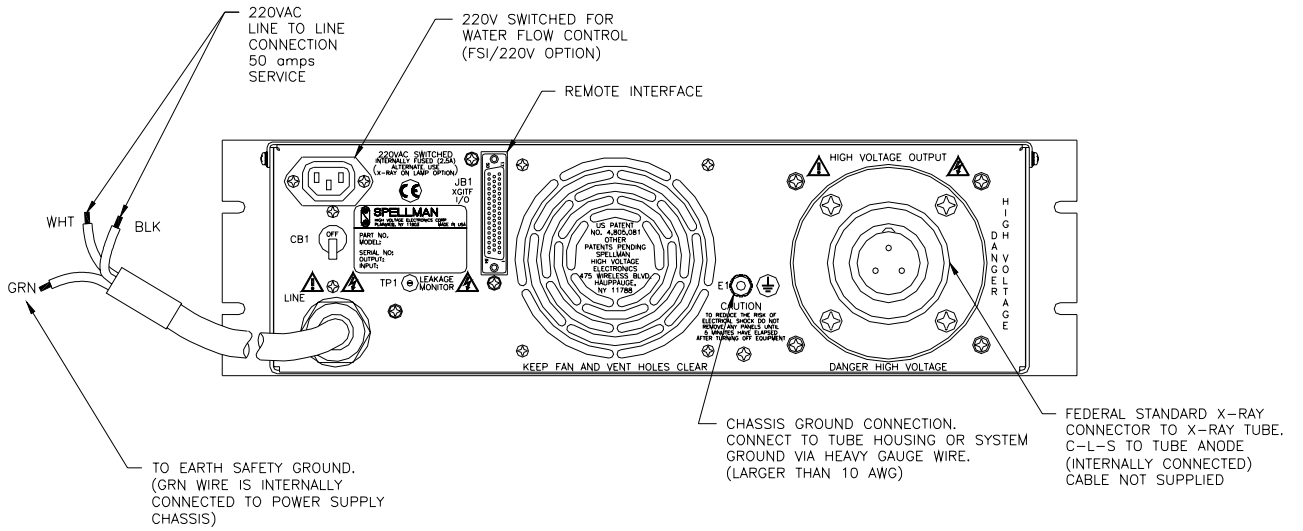

FIG 3.1B DF3 TYPICAL OPERATING SETUP

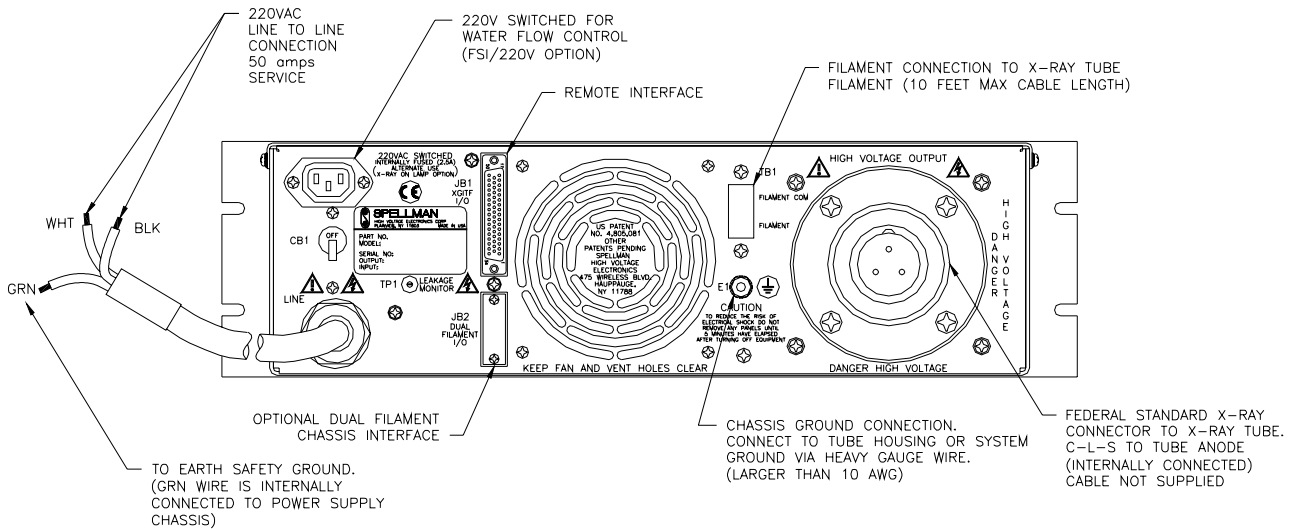

FIG. 3.1C FF3 TYPICAL OPERATING SETUP

- S1 must be closed for INTERLOCK CLOSED.
- It is recommended to use relay contacts for S1.
- Relay should be located as close as possible to High Voltage power supply.
- Relay coil should be driven from an isolated source.
- All cables should be shielded with shields being returned to chasses ground, E1, of the High Voltage power supply.

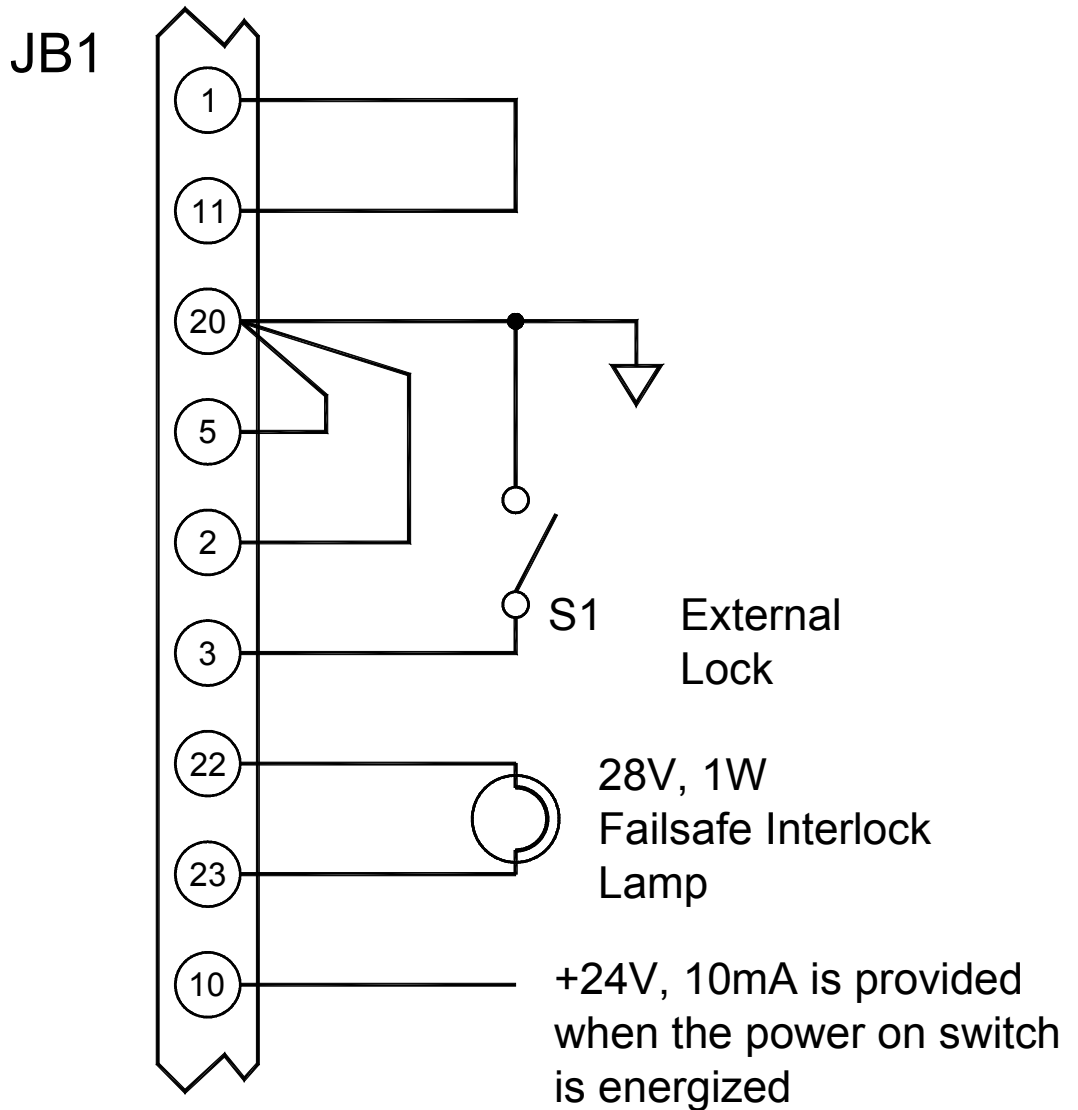

FIGURE 3.1D WIRING DIAGRAM FOR JB1 WHEN NO REMOTE OPERATION IS DESIRED

I) Turn CB1 to the ON position. The DF3/FF3 power supplies have internal circuit protection (circuit breaker). It is good practice to provide external circuit protection also. Depending on input voltage requirement, the line current requirements will vary. Typically, a 50Amp service is advised. If unsure of service requirements, consult Spellman's Engineering Department.

CB1 can now remain in the ON position and power can be turned ON and OFF via the control power ON switch.

Depress the Control Power ON switch. The lamps will illuminate. The X-ray OFF lamps will also illuminate. The front panel meters will illuminate and display zero for all output functions. Interlock closed/open lamp will illuminate displaying status of external interlock connections.

J) Presetting: Depress and hold the X-ray off switch. The kV, mA, filament current limit and maximum tube power limit can now be preset. NOTE: No output will be generated even though the meters are displaying in the preset mode. It is suggested to set kV to a minimum value, (10 kV-20kV). If kV is set too low the kV MIN indicator will illuminate. Simply raise the kV level if this occurs. Set mA level to a minimum value (5mA). Filament current and tube power limit should be set as required by the X-ray tube manufacturer. Release the X-ray OFF switch.

K) X-ray ON: After presetting desired levels, depress and release the X-ray ON switch. The X-ray ON indicator will illuminate. The remote X-ray lamp will also illuminate. kV and mA will ramp to set levels as controlled by internal ramp circuits. Once kV and mA levels are reached, (2-20 seconds) adjust kV and mA for desired output.

L) To terminate the generation of X-rays, depress the X-ray OFF switch.

M) To turn off the power supply, depress the Control Power ON Switch (out).

WARNING

After turn off, do not unplug the output cable until the internal capacitance is discharged (approximately 1 minute).

WARNING

The voltmeter on the power supply front panel does not read the output voltage when the Control Power is turned off, even if a charge still exists on the load.

CAUTION

Always operate the unit with the cover on. A fan maintains safe operating temperature in the power supply by drawing air over critical components. The cover must be on in order to direct the airflow over the areas that need cooling. In operation, the unit must be placed so that the air intake and the fan exhaust are clear of any obstruction that might impede the flow of air.

3.2 STANDARD FEATURES:

A note on remote interface circuitry and remote signal grounding:

Whenever possible, electrical isolation should be provided when interfacing with any high voltage power supply. For remote control signals such as POWER ON/OFF, X-RAY ON/OFF, EXTERNAL INTERLOCK, etc., isolated power and grounding from the power supply should be used. The DF/FF series provides isolated relay coils for the above signals. (See suggested interface).

Other digital status signals provided on the DF3 series should be interfaced using opto-isolators. If possible, analog signals should be isolated via analog isolation amplifiers. All interface cables should be properly shielded. All power supply signals should be referenced to the power supply chassis ground.

Spellman application engineers are available to assist in interface circuitry design

3.2.1 REMOTE PROGRAMMING:

Allows remote adjustment of the tube voltage, tube current, filament current limit, and maximum tube power limit, via external voltage source. In Local Control (front panel control), programming signals are connected by two octal DIP switches and a 4 pole relay. When remote control is used, the appropriate DIP switch locations and Remote Reference Enable pin (JB1-9) should be changed to the remote position. See Table 3.1 for the correct settings for remote and/or local operation.

For remote program, the desired DIP switch selection is set, and a positive voltage source, from 0 to 10V =0-100%, is applied to the appropriate terminals on the rear panel 50-pin D connector (see Table 3.3 for pin description of 50 pin I/O connector). By adjusting the voltage source from 0 volts (zero output) to 10 volts (full rated output) the desired output can be selected. See Figure 3.2 for wiring diagram and specifications for remote program interface requirements.

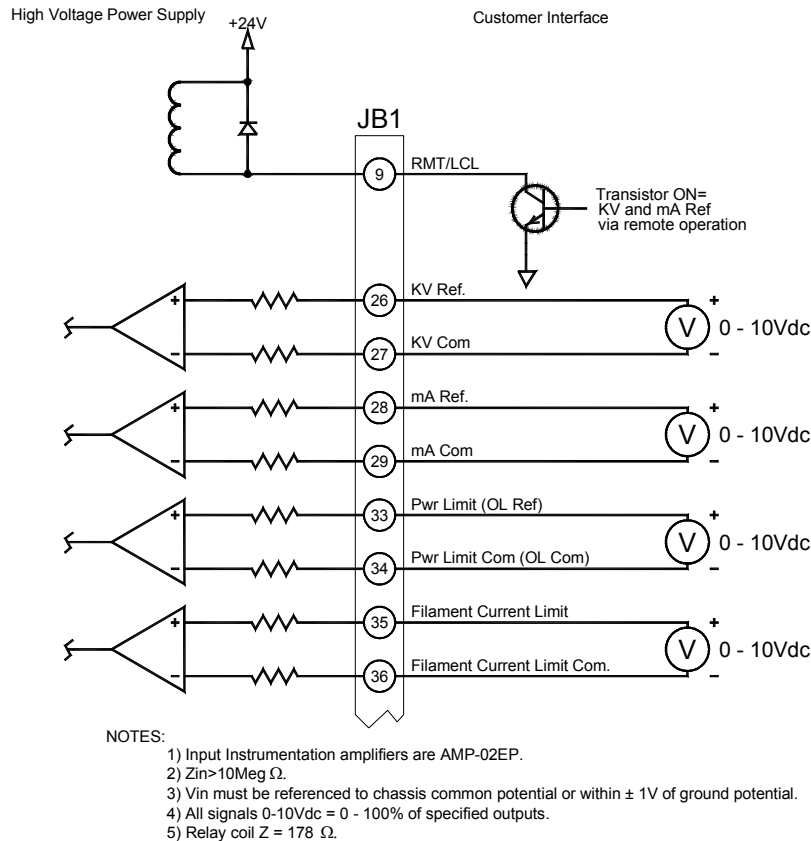

Figure 3.2 REMOTE CONTROL

TO REMOTE PROGRAM	DIP SWITCH 1 (RN1).	DIP SWITCH 2 (RN2)	PIN JB1-9
TUBE VOLTAGE	N/A	N/A	GROUND
TUBE CURRENT	N/A	N/A	GROUND
POWER LIMIT	SWITCH 3 OFF	SWITCH 3 OFF	N/A
FILAMENT LIMIT	SWITCH 4 OFF	SWITCH 4 OFF	N/A
COMPLETE REMOTE	SW3 AND SW4 OFF	SW3 AND SW4 OFF	GROUND
COMPLETE LOCAL	ALL ON	ALL ON	OPEN

Table 3.1 LOCAL/REMOTE OPERATION

3.2.2 REMOTE MONITOR:

Test points are made available at the rear 50-pin connector from monitoring tube voltage, tube current and tube filament current. Also, tube voltage programming and tube current programming readback signals are provided. The test points are always positive regardless of the output polarity, where 0 to 10V = 0-100% of

output. Accuracy is within $\pm 0.5\%$. All test points have output impedance at 1Kohm. See Figure 3.3 for remote monitor interface.

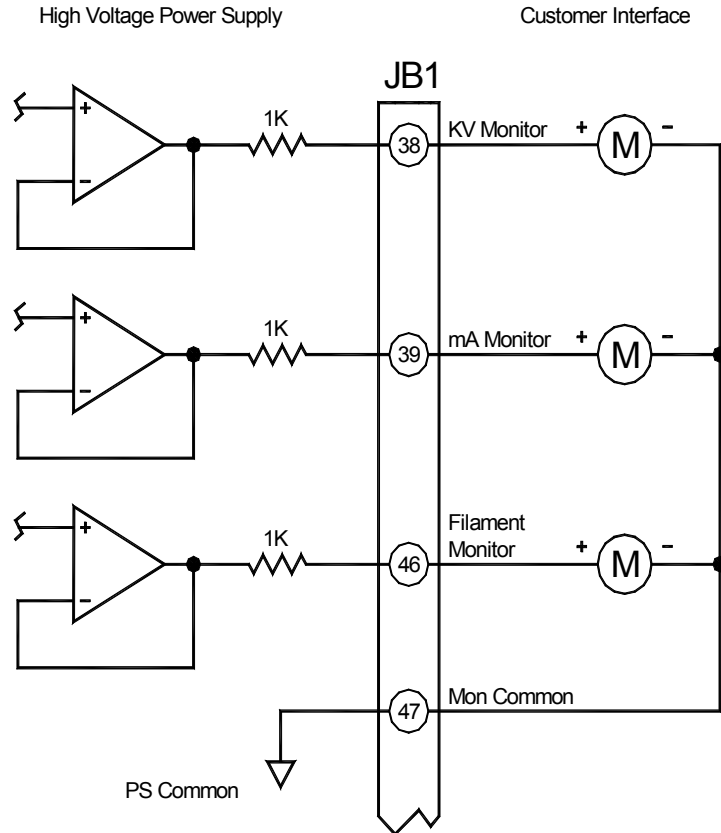

NOTES:

- 1) Metering Circuit should be high Z type (>10 Meg) for accurate measurement.
- 2) All signals 0 - 10Vdc = 0 - 100% of specified maximum outputs.

Figure 3.3 REMOTE MONITOR

3.2.3 REMOTE CONTROL:

Remote control of the POWER ON, X-RAY OFF, X-RAY ON, and INTERLOCK, are available on the rear 50-pin connector. The POWER ON control is a toggle on/off type signal. X-RAY OFF and X-RAY ON are controlled by momentary normally closed and

normally open contacts respectively. If remote control is required, the remote interface dummy plug must be removed and replaced with the appropriate remote circuits. See Figure 3.5 for recommended interface circuits.

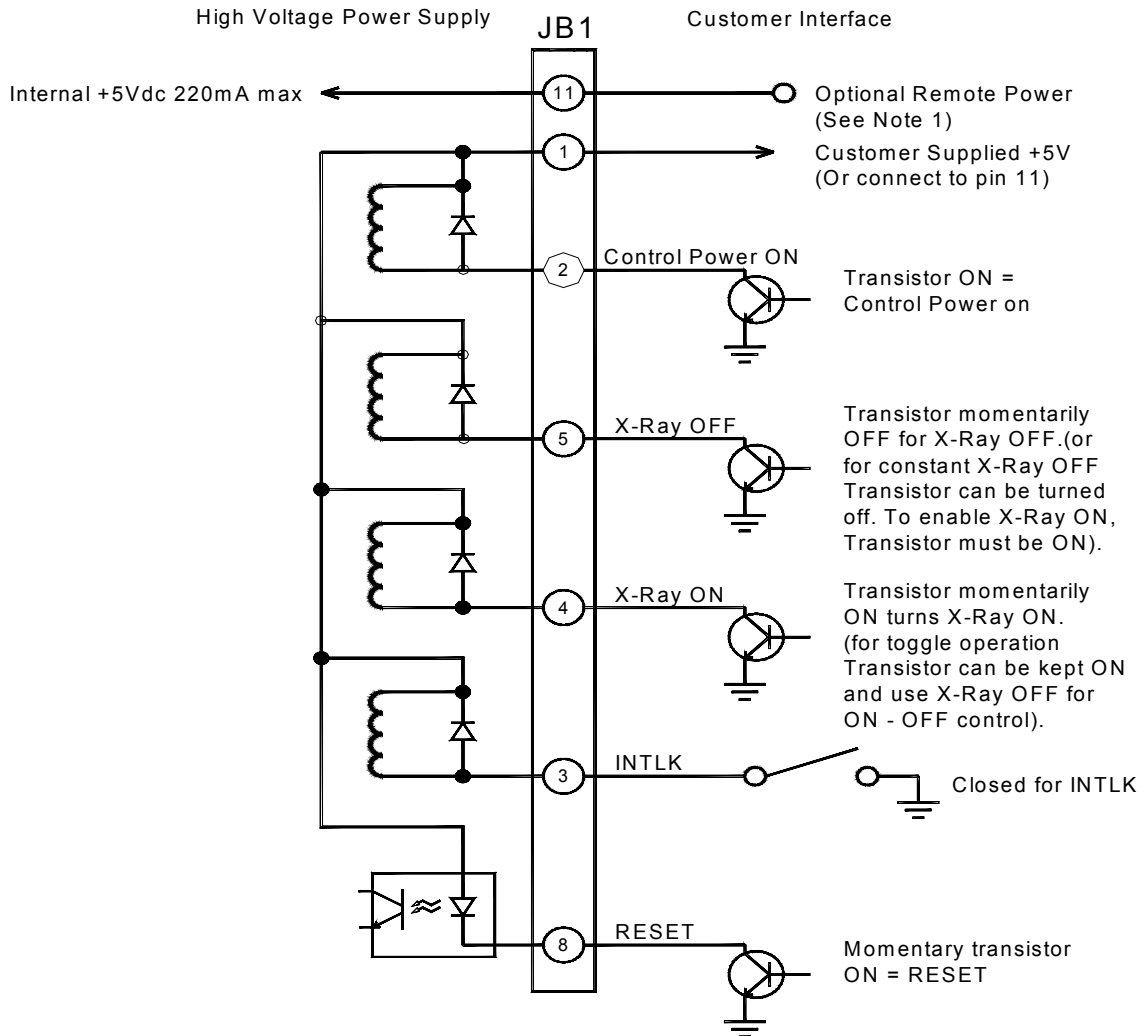

NOTES:

- 1) The power supply provides +5Vdc for coil voltage, however for full isolation, an external customer supplied +5Vdc power is suggested.
- 2) Relay coil Z = 178 Ω.
- 3) \perp should be referenced to chassis ground.
- 4) Relay contacts or switches can be used instead of transistors.

Figure 3.4 REMOTE ON/OFF CONTROL

3.2.4 REMOTE STATUS:

Remote status signals for KV MIN tube current limit, tube power limit, overvoltage, filament current limit, and power supply fault is provided.

These signals are open collector type. (Normally off), and are intended to drive the diode of an opto-coupler. See Figure 3.5 for recommended interface circuits.

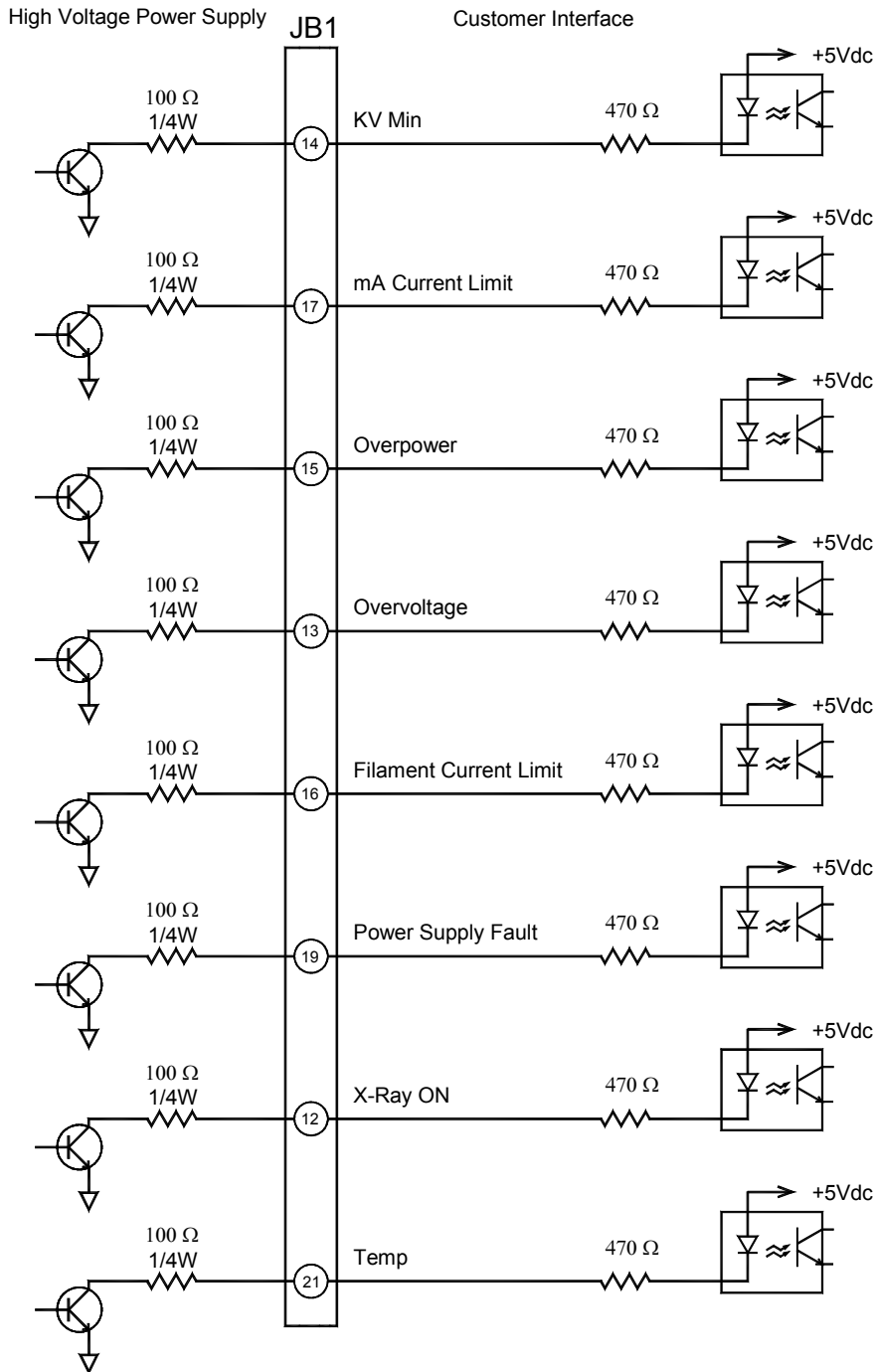

NOTES:

- 1) 100 mA max collector current on internal power supply transistors.
- 2) Low level on transistor = status active.

Figure 3.5 REMOTE STATUS INDICATORS

3.2.5 REMOTE FAIL-SAFE X-RAY ON CIRCUITS:

The DF3 series provides a 24VDC circuit for a remote X-RAY ON lamp. This circuit provides fail-safe sensing of the lamp. (The front panel X-Ray on lamps are also fail-safe sensed). Optional 12VDC and 220VAC lamps can be accommodated. See Figure 3.6A and 3.6B for remote fail-safe connections.

3.2.6 REMOTE WATER SOLENOID CONTROL SIGNAL:

Remote signals are provided for tube water flow control and other uses. +24V and 220VAC signals are provided. These signals are switched ON when X-RAY ON is switched on. These signals can also be controlled (independently) when the power supply is switched ON. This is accomplished on the rear panel INTERFACE PWB. JP2 controls the 24V signal and JP3 controls the 220V signal. See Figure 3.7 for remote water flow connections. External interlock connections can also be used for water flow interlock as shown in Figure 3.7.

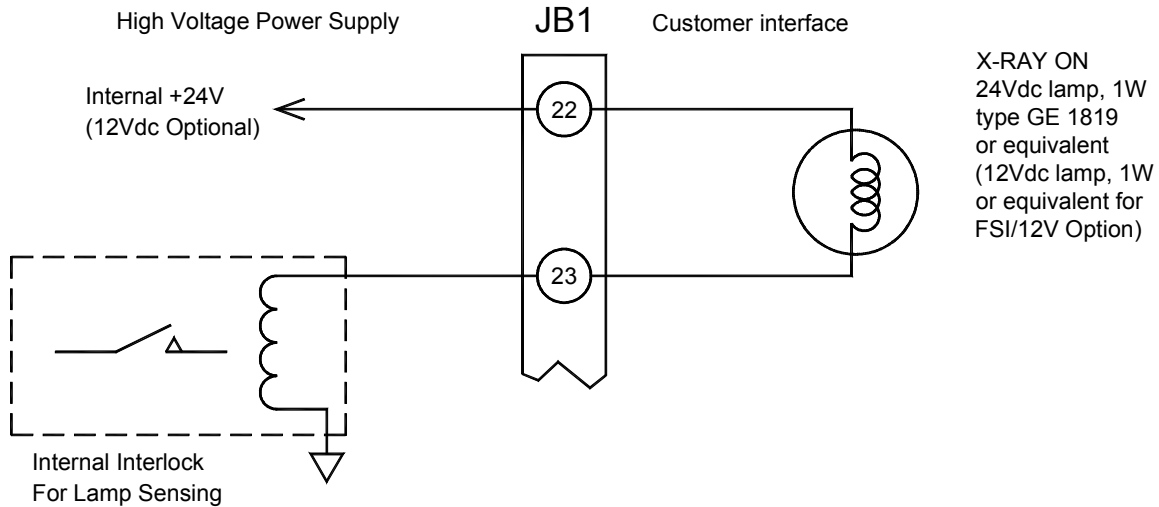

Figure 3.6A REMOTE FAIL SAFE INDICATOR 24V dc

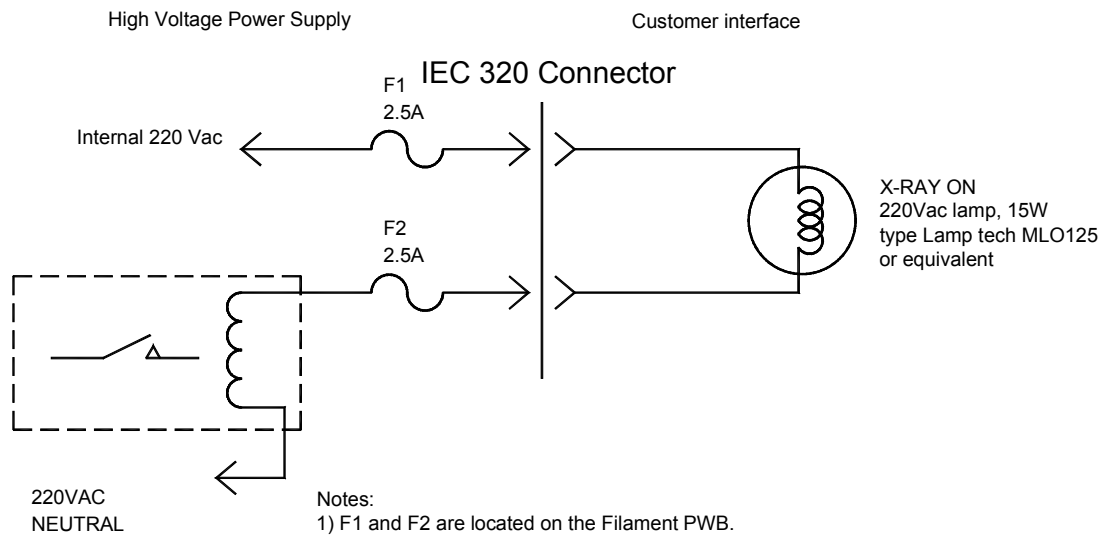

Figure 3.6B OPTIONAL REMOTE FAIL SAFE INDICATOR (220v AC)

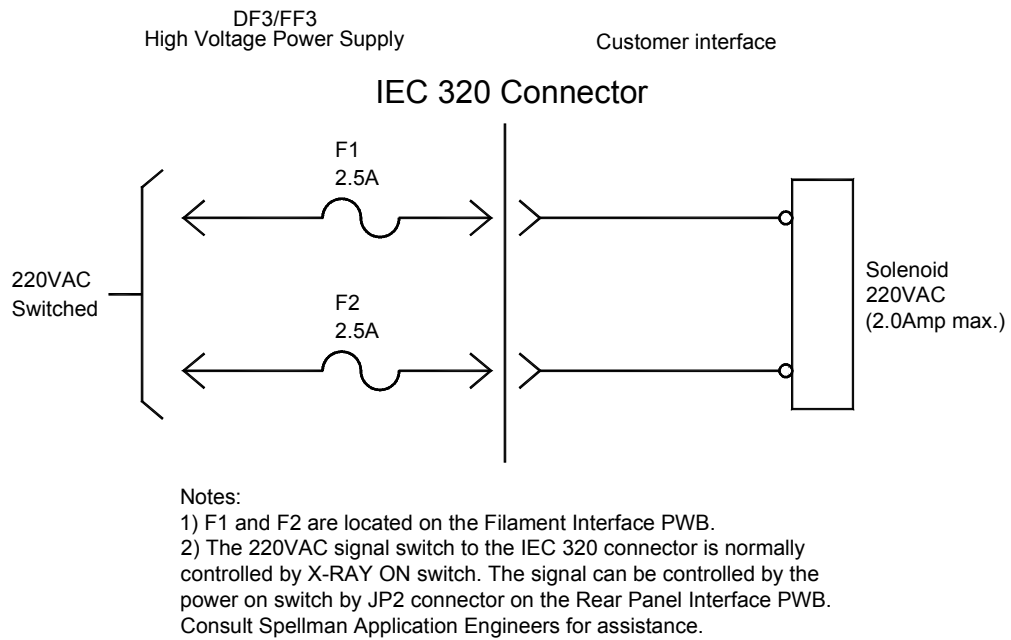

Figure 3.7 REMOTE WATER SOLENOID CONTROL

4 PRINCIPLES OF OPERATION

The DF3/FF3 series of high voltage power supplies utilize sophisticated power conversion technology. A variety of analog, digital and power conversion techniques are used throughout. The intention of the Principles of Operation is to introduce the basic function blocks that comprise the DF3/FF3 power supply. For details on a specific circuit, consult Spellman's Engineering Department.

See Table 4.1 for a list of the main assemblies found in a typical DF3/FF3 power supply.

The DF3/FF3 power supply is basically an AC to DC power converter. Within the power supply, conversions of AC to DC, then to high frequency AC, then to high voltage DC take place. By reviewing further the sub-assemblies, a basic understanding of the process can be gained.

4.1 CHASSIS

The DF3/FF3 is a compact, high efficiency, high voltage power supply. The power supply can supply three kilowatts of DC power as well as a regulated filament output.

WARNING:

The energy levels used and generated by the power supply can be lethal! Do not attempt to operate the power supply unless the user has a sufficient knowledge of the dangers and hazards of working with high voltage. Do not attempt to approach or touch any internal or external circuits or components that are connected or have been connected to the power supply. Be certain to discharge any stored energy that may be present before and after the power supply is used. Consult IEEE recommended practices for safety in high voltage testing #510-1983.

4.2 LINE RECTIFICATION AND FILTERING

Basic AC line rectification provides the DC voltage for the high frequency inverter and the filament supply.

The FILTER CAP. ASSEMBLY and main chassis components comprise the circuits for line voltage rectification. The line input voltage can vary from 180 up to 242 volts within the DF3/FF3 series. In general, the following variations can be ordered.

200Vac $\pm 10\%$, 50/60Hz, 400Hz, three phase or single phase.

208Vac $\pm 10\%$, 50/60Hz, 400Hz, three phase or single phase.

220Vac $\pm 10\%$, 50/60Hz, 400 Hz, three phase or single phase.

400Hz exceed leakage current limits.

Other input voltages can be accommodated. If the user is unsure of which input voltage option is supplied, check the serial tag on the rear of the power supply or consult Spellman Sales Department.

Circuit protection is provided by CB1 (SYSTEM BLOCK DIAGRAM CHASSIS DF3/FF3 SCHEMATIC). CB1 is a fast acting circuit breaker. The line input is connected directly to the line side of the CB1. The load side is connected to K1. K1 is a definite purpose contactor. K1 provides fail safe type disconnection of the line voltage to power supply rectification circuits. K1 coil is controlled by variety of circuit conditions, which will be described later on. The load side of CB1 is also connected to the low voltage power supply. The LVPS supplies +5V, $\pm 15V$ and +24V dc to the control electronics.

WARNING

Line voltage is present whenever the power supply is connected to external line voltages. Be sure to disconnect the line cord before opening the unit. Allow 5 minutes for internal capacitance to discharge before removing any cover.

ASSEMBLY TITLE	ASSEMBLY DRAWING NO.	SCHEMATIC DRAWING NO.
DF3 Chassis	403804-001	440469-007
FF3 Chassis	403805-001	440469-008
IGBT PWB	405102-001	440785-001
System Control PWB	450008-TAB	440716-001
High Voltage Assembly (DF3)	403732-001	440461-001
High Voltage Assembly (FF3)	403733-001	440461-002
Front Panel Assembly	403789-TAB	440443-TAB
Rear Panel Interface PWB	450001-TAB	440500-TAB
Filament Power PWB	404450-TAB	440461-001

Table 4.1 DF3/FF3 MAIN ASSEMBLIES

When K1 is energized, voltage is applied to CR1. CR1 is an isolated diode power module. It contains the rectifier diodes used for line voltage rectification. K1 voltage also supplies power to fans used throughout the chassis for cooling purposes. The output of CR1 is connected to a capacitor filter. Capacitor C1 is initially charged through a charging resistor. This resistor is located on the IGBT PWB.

Approximately 1 second after K1 contactor closure occurs, a relay is energized to short the charging resistor. This relay is K2. The DC voltage on C1 is approximately 1.4 times the input voltage. This DC voltage is supplied to the high frequency inverter through L2, L3, on the filter cap assembly. These inductors provide isolation for the high frequency inverter if a cross conduction or “shoot thru” occurs. Hence, L1 and L2 are termed shoot thru chokes.

The IGBT PWB provides a variety of control and diagnostic functions. R13, R14 are the charging resistors previously described. These resistors limit the initial charging current for the capacitors used for lone rectification. U1 and its associated circuitry monitor the voltage across the charging resistor. If any abnormal conditions appear, circuitry will shutdown the power supply. R38 is a bleeder resistor, which is used to discharge the filter capacitor. DS1 provides visual indication

when DC voltage is present. This indicator should not be relied on for confirming the presence or absence of the DC voltage. Integrated circuits provide logic control for AC fault conditions, contactor control and relay control.

4.3 INVERTER

The inverter is a series resonant, series loaded topology. A patented control scheme is used for regulating the power generated from the inverter. Q1 and Q2 are high speed dual IGBT. These devices provide high frequency switching to control the resonant current flow. The typical resonant operating period is approximately 20uSeconds. The gate control for the switching devices is provided by the IGBT PWB. VCO1 and VCO2 signals are generated by the SYSTEM CONTROL PWB. The IGBT PWB provides the required gate pulse width and phase control.

4.4 HIGH VOLTAGE TRANSFORMER

The output of the High Frequency Resonant Inverter is connected to the primary of the High Voltage Transformer. The High Voltage Transformer is a step up type. Typical secondary voltages are in the range of 1kV to 4.5kV depending upon output voltage ratings.

4.5 HIGH VOLTAGE ASSEMBLY

The High Voltage Assembly will vary depending upon the model ordered. The circuitry typically consists of a series arrangement of full wave voltage doublers.

Voltage feedback for regulation and monitoring is provided by a high band width resistive/capacitive divider. Current feedback for regulation and monitoring is provided by a sense resistor connected at the low end of the High Voltage Rectifier.

4.6 SYSTEM CONTROL PWB

The majority of control circuits for power supply controls are located on the SYSTEM CONTROL PWB. For trouble shooting and testing purposes, this board can be easily accessed by removing the four #10 screws on the side near the front panel. The front panel will hinge down allowing for easy access to the SYSTEM CONTROL PWB.

+5V dc, +15V dc, -15V dc, and +24V dc, is sent to the system control PWB from the low voltage power supply via JB7. X-RAY On/Off control is accomplished by K2, and its associated circuitry. Interlock control is also provided by auxiliary contact of K2. System shutdown is accomplished by U2. K1 provides control power On/Off switching. U1 provides a precision 10V dc reference programming kV, mA and other references.

Voltage feedback from the high voltage divider is sent to U3. Gain adjustment is provided by R55 (KVFBK CAL). The KV feedback signal is sent to the front panel DVM and to the REAR PANEL INTERFACE PWB for remote monitoring. K3 provides switching between feedback and program signal for the front panel DVM's. This allows the user to preset the desired output before energizing high voltage.

Program voltages are typically ramped up to set level by the slow start circuits of U8.

Arc sense circuits T1 and U6 provide sensing, quench and indication of arc conditions.

Current feedback from the high voltage rectifier is sent to sense resistors R56, R24, and R57. U10 provides gain adjustment (MAFDBK CAL).

An over voltage protection divider located in the HIGH VOLTAGE ASSEMBLY provides protection in the unlikely event of a main control loop failure. U14 provides gain adjustments for the over voltage protection (OVP) control.

U9, U18 and U12 circuits provide sensing of mA, kV, fil and power status. These signals are sent to the PLD, U27 for processing.

The series resonant control circuitry consists of a voltage frequency and a voltage to phase converter. U17 generates all frequency and phase controls. PLD, U27, provides specific phase control functions for the VCO1 and VCO2 signals.

Signals from the AC PWR/CONTROL PWB, the INVERTER DRIVE PWB, and the REAR PANEL INTERFACE PWB are used for control of the power supply and are processed by PLD, U27.

System Fault Control and Indication is provided by U26, U27, U29, U30 and associated circuitry. Diagnostic signals are latched and then sent to the FRONT PANEL ASSEMBLY for status indication. U28 provides power up and remote reset functions.

U25 provides RMS to DC conversion for the AC filament current sense transformer. U22 and U23 provide the regulation control and frequency modulation drive pulses for the filament inverter.

4.7 FRONT PANEL ASSEMBLY

Front Panel controls, meters, and status indications are connected to the FRONT PANEL PWB. The FRONT PANEL PWB interfaces directly to the SYSTEM CONTROL PWB. LCL/RMT relay switch control is provided by K2 and K3.

4.8 REAR PANEL INTERFACE PWB

Signals going to and from the remote interface are sent to the REAR PANEL INTERFACE PWB. The REAR PANEL INTERFACE PWB connects directly to the SYSTEM CONTROL PWB. The rear panel interface provides isolated relay coils, optocouplers and open collector type signals for remote connection.

4.9 FILAMENT POWER PWB

The power for the X-ray tube is provided by the filament inverter. The filament inverter is a high frequency, series resonant inverter. The inverter provides regulated current to the primary of the filament isolation transformer. The filament isolation transformer secondary is connected to the output connector. For the DC filament option, the transformer secondary is connected to a full wave rectifier and then to the output connector.

4.10 OPTIONS

Due to many variations of models and options provided in the DF3/FF3 series, details of actual circuits used may differ slightly from above descriptions. Consult Spellman's Engineering Department for questions regarding the principles of operation for the DF3/FF3 series.

5 OPTIONS

The options available for this power supply are described in this section. Options are specified by including the option code in the model number as described in Section 1.5.

5.1 208V AC THREE PHASE INPUT 3 PH

DF3/FF3 power supplies with the 208Vac input option will operate from an input voltage of 208Vac rms $\pm 10\%$, 50-60Hz, three phase.

5.2 HIGH STABILITY HS

20ppm/ $^{\circ}\text{C}$ temperature coefficient is available for both voltage and current regulation.

5.3 220VAC FAIL SAFE CIRCUIT FSI (220V)

Remote Fail-Safe circuit operating at 220Vac is available. This replaces the standard WFS 220V circuit.

5.4 12VDC FAIL SAFE CIRCUIT FSI (12V)

Remote Fail-Safe circuit operating at 12Vdc is available. 24Vdc is standard.

5.5 24VDC WATER FLOW SIGNAL WFS (24V/PO)

24Vdc water flow signal is switched with POWER ON. The standard configuration is switched with X-RAY ON.

5.6 220VAC WATER FLOW SIGNAL WFS (220V/PO)

220Vac water flow signal is switched with POWER ON. The standard configuration is switched with X-RAY ON. This option is not available with FSI (220V).

5.7 DUAL FILAMENT SUPPLY DFS

A dual filament supply is available on FF3 models only. This option allows the FF3 to power Varian DTS-68 X-Ray tubes and equivalents.

5.8 4kW OUTPUT 4kW

4kW maximum power is available. On FF3 units, maximum current is limited to 80 mA (100mA is standard on 3kW FF3).

5.9 ELAPSED TIME METER ETM

An elapsed time meter is provided. It displays cumulative hours of X-RAY ON.

5.10 LARGE-COMMON LC

The standard DF/FF output connections are Common = 60kV, L and S = filament output. The LC option ties L and C together and has the filament on S.

5.11 NON-STANDARD SLOW START SS(x)

The non-standard slow start option allows the gradual rise time of the output voltage to be different from the standard. To order the option place the time desired in seconds after the suffix letter; i.e. SS(10) denotes a 10 second rise time.

5.12 SLIDES SL

Units can be supplied with slides that mount into a standard EIA 19" wide rack.

5.13 CUSTOM DESIGNED MODELS X(#)

Units built to customer specifications are assigned an X number by the factory. If this unit is an X model, a specification control sheet is added at the end of this instruction manual.

Spellman welcomes the opportunity to tailor units to fit your requirements or to develop new products for your applications. Contact the Spellman Sales Department with your needs.

6 MAINTENANCE

This section describes periodic servicing and performance testing procedures.

WARNING:

THIS POWER SUPPLY GENERATES VOLTAGES THAT ARE DANGEROUS AND MAY BE FATAL. OBSERVE EXTREME CAUTION WHEN WORKING WITH HIGH VOLTAGE.

6.1 PERIODIC SERVICING

Approximately once a year, (more often in high dust environments), disconnect the power to the unit and remove the top cover. Use compressed air to blow dust out of the inside of the unit. Avoid touching or handling the high voltage assembly. Be sure that the fans are not obstructed and spin freely. The fans have sealed bearings and do not need lubrication. Be sure to replace the top cover before operating for proper cooling.

6.2 PERFORMANCE TEST

WARNING:

HIGH VOLTAGE IS DANGEROUS. Only qualified personnel should perform these tests.

High voltage test procedures are described in Spellman Bulletin STP-783, Standard Test Procedures for High Voltage Power Supplies. Copies can be obtained from the Spellman Customer Service Department. Test equipment, including an oscilloscope, a high impedance voltmeter, and a high voltage divider such as the Spellman HVD-100 or HVD-200, is needed for performance tests. All test components must be rated for operating voltage.

6.3 HIGH VOLTAGE DIVIDERS

High voltage dividers for precise measurement of output voltage with an accuracy up to 0.1% are available from Spellman. The HVD-100 is used for voltages up to 100kV. The HVD-200 measures up to 200kV. The Spellman divider is designed for use with differential voltmeters or high impedance digital voltmeters. The high input impedance is ideal for measuring high voltage low current sources, which would be overloaded by traditional lower impedance dividers.

7 REPLACEMENT PARTS

7.1 REPLACEMENT PARTS

Contact the Spellman Customer Service Department for parts lists for specific models.

Spellman provides parts and subassemblies for its high voltage power supplies but recommends that only qualified personnel perform the repairs. High voltage is dangerous; even minor mistakes in repairs can have serious consequences.

When requesting parts please give the model number and serial number of the power supply.

7.2 CORRESPONDENCE AND ORDERING SPARE PARTS

Each Spellman power supply has an identification label on the rear of the chassis that bears its model and serial number.

When requesting engineering or applications information, please state the model and serial number of the power supply. If specific components or circuit sections are involved in the inquiry, it is helpful to indicate the component symbol number(s) shown on the applicable schematic diagram.

When ordering spare parts, please specify the Spellman part number, the component function and symbol from the schematic, and the model and serial number of the unit.

8 FACTORY SERVICE

8.1 Warranty Repairs

During the warranty period, Spellman will repair all units free of charge. The warranty is void if the unit is worked on by other than Spellman personnel. See the warranty in the rear of this manual for more information. Follow the return procedures described in section 6.2. The customer shall pay for shipping to and from Spellman.

8.2 Factory Service Procedures

Spellman has a well-equipped factory repair department. If a unit is returned to the factory for calibration or repair, a detailed description of the specific problem should be attached.

For all units returned for repair, please obtain an authorization to ship from the customer service department, either by phone or mail prior to shipping. When you call, please state the model and serial numbers, which are on the plate on the rear of the power supply, and the purchase order number for the repair. A return Material Authorization Code number (RMA Number) is needed for all returns. This RMA number should be marked clearly on the outside of the shipping container. Packages received without an RMA number will be returned to the customer. The customer shall pay for shipping to and from Spellman.

A preliminary estimate for repairs will be given by phone by Customer Service. A purchase order for this amount is requested upon issuance of the RMA Number. A more detailed estimate will be made when the power supply is received at Spellman Repair Center. In the event that repair work is extensive, Spellman will call to seek additional authorization from your company before completing the repairs.

8.3 Ordering Options and Modifications

Many of the options listed in chapter 5 can be retrofitted into Spellman's power supplies by our factory. For prices and arrangements contact the Spellman sales department.

8.4 Shipping Instructions

All power supplies returned to Spellman must be sent shipping prepaid. Pack the units carefully and securely in a suitable container, preferably in the original container, if available. The power supply should be surrounded by at least four inches of shock absorbing material. Please return all associated materials, i.e. high voltage output cables, interconnection cables, etc., so that we can examine and test the entire system.

All correspondence and phone calls should be directed to:

Spellman High Voltage Electronics Corp
475 Wireless Boulevard
Hauppauge, New York, 11788
TEL: (631) 630-3000
FAX: (631) 435-1620
E-mail: sales@spellmanhv.com
<http://www.spellmanhv.com>

SPELLMAN HIGH VOLTAGE ELECTRONICS

WARRANTY

Spellman High Voltage Electronics ("**Spellman**") warrants that all power supplies it manufactures will be free from defects in materials and factory workmanship, and agrees to repair or replace, without charge, any power supply that under normal use, operating conditions and maintenance reveals during the warranty period a defect in materials or factory workmanship. The warranty period is twelve (12) months from the date of shipment of the power supply. With respect to standard SL power supplies (not customized) the warranty period is thirty-six (36) months from the date of shipment of the power supply.

This warranty does not apply to any power supply that has been:

- Disassembled, altered, tampered, repaired or worked on by persons unauthorized by **Spellman**;
- subjected to misuse, negligent handling, or accident not caused by the power supply;
- installed, connected, adjusted, or used other than in accordance with the original intended application and/or instructions furnished by **Spellman**.

THE FOREGOING WARRANTY IS IN LIEU OF ALL OTHER WARRANTIES, EXPRESS OR IMPLIED, INCLUDING THOSE OF MERCHANTABILITY OR FITNESS FOR A PARTICULAR PURPOSE.

The buyer's sole remedy for a claimed breach of this warranty, and **Spellman's** sole liability is limited, at **Spellman's** discretion, to a refund of the purchase price or the repair or replacement of the power supply at **Spellman's** cost. The buyer will be responsible for shipping charges to and from **Spellman's** plant. The buyer will not be entitled to make claim for, or recover, any anticipatory profits, or incidental, special or consequential damages resulting from, or in any way relating to, an alleged breach of this warranty.

No modification, amendment, supplement, addition, or other variation of this warranty will be binding unless it is set forth in a written instrument signed by an authorized officer of **Spellman**.

Factory Service Procedures

For an authorization to ship contact **Spellman's** Customer Service Department. Please state the model and serial numbers, which are on the plate on the rear panel of the power supply and the reason for return. A Return Material Authorization Code Number (RMA number) is needed from **Spellman** for all returns. The RMA number should be marked clearly on the outside of the shipping container. Packages received without an RMA Number may delay return of the product. The buyer shall pay shipping costs to and from **Spellman**. Customer Service will provide the Standard Cost for out-of-warranty repairs. A purchase order for this amount is requested upon issuance of the RMA Number (in-warranty returns must also be accompanied by a "zero-value" purchase order). A more detailed estimate may be made when the power supply is received at **Spellman**. In the event that the cost of the actual repair exceeds the estimate, **Spellman** will contact the customer to authorize the repair.

Factory Service Warranty

Spellman will warrant for three (3) months or balance of product warranty, whichever is longer, the repaired assembly/part/unit. If the same problem shall occur within this warranty period **Spellman** shall undertake all the work to rectify the problem with no charge and/or cost to the buyer. Should the cause of the problem be proven to have a source different from the one that has caused the previous problem and/or negligence of the buyer, **Spellman** will be entitled to be paid for the repair.

Spellman Worldwide Service Centers

For a complete listing of **Spellman's** Global Service facilities please go to:
<http://www.spellmanhv.com/customerservice/service.asp>

THIS INFORMATION CONTAINED HEREIN IS PROPRIETARY TO SPELLMAN HIGH VOLTAGE ELECTRONICS CORP. AND IS TO BE USED ONLY FOR THE PURPOSES INTENDED AND IS NOT TO BE REPRODUCED EITHER IN WHOLE OR PART WITHOUT THE EXPRESS WRITTEN PERMISSION OF SPELLMAN HIGH VOLTAGE ELECTRONICS CORP.

REVISIONS		APPROVED				
LTR	DESCRIPTION	DATE	MECH. DESIGN	PROJ. ENG.	QUALITY	MFG. ENG.
A	RELEASED PER EDR 4316	4/4/97	J.P.	J.P.	J.C.	L.B.
A1	REVISED PER ECN NO. 11896	10/2/98	J.C.	J.P.	J.C.	L.B.

DESCRIPTION OF HOLES		
SYM	DESCRIPTION	QTY

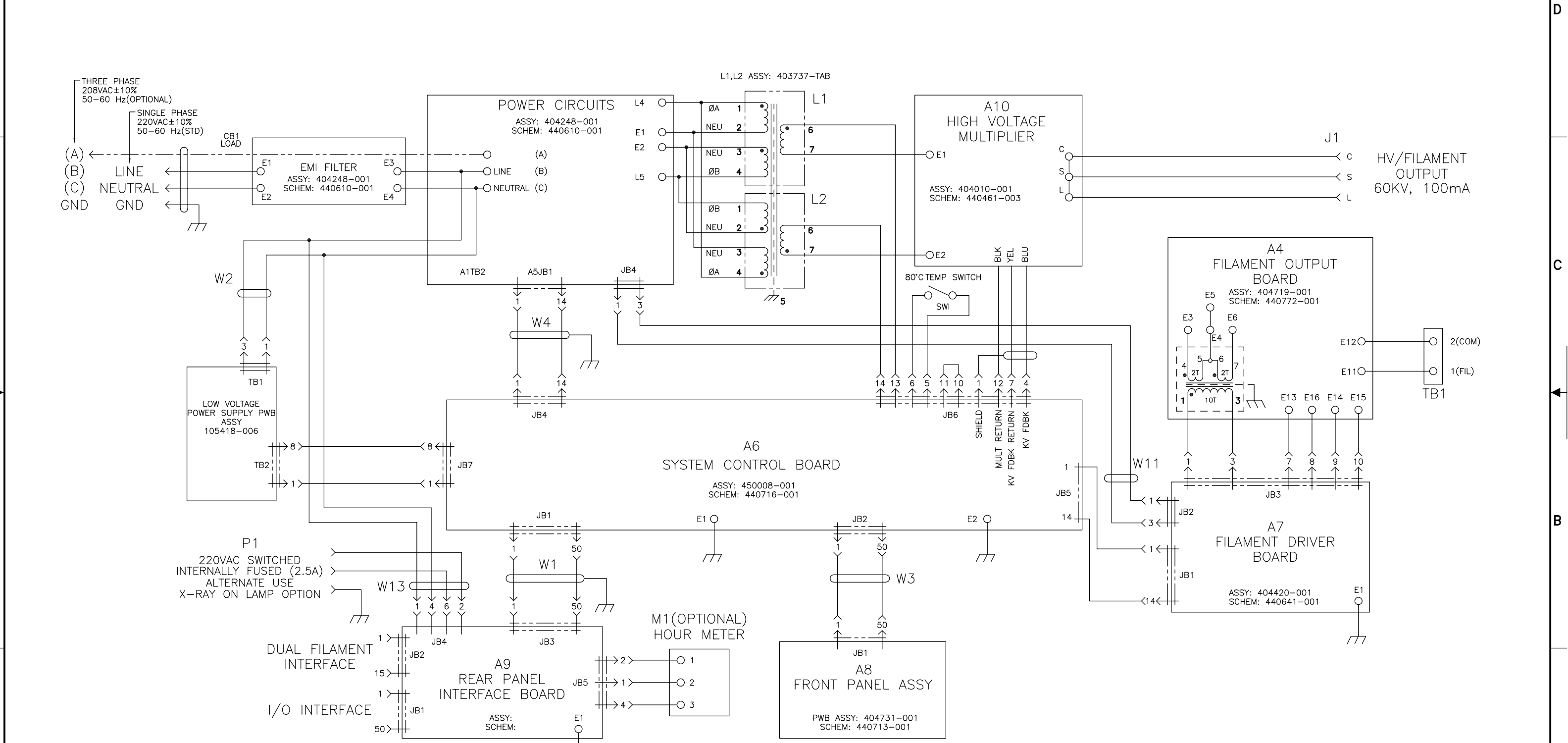

HV/FILAMENT OUTPUT
60KV, 100mA

UNLESS OTHERWISE SPECIFIED DIMENSIONS ARE IN INCHES TOLERANCES ARE:			APPROVALS		 475 WIRELESS BLVD. HAUPPAUGE, NEW YORK 11788
FRACTIONS	DECIMALS	ANGLES	BY	DATE	
±	.XX ±	±	<i>Ken Leung</i>	11/18/96	BLOCK DIAGRAM, POWER SUPPLY ASSEMBLY X2545
±	.XXX	±	<i>N/A</i>	N/A	
MATERIAL	CHECKED	<i>M.L.</i>	3/27/97		
	MECH. DESIGN	<i>M.L.</i>	3/27/97		
	PROJ. ENG.	<i>J.P.</i>	4/1/97		
FINISH	Q.A.	<i>J.C.</i>	3/28/97		SIZE: D 10610 CODE IDENT NO.: 440469-006 DRAWING NO.: A1
	MFG. ENG.	<i>N/A</i>	N/A		SCALE: NONE FILE#: 440\469006A1 SHEET 1 OF 1

PART NO.	NEXT ASSY	USED ON
		X2545
APPLICATION		

DO NOT SCALE DRAWING

BREAK ALL SHARP EDGES & CORNERS

THIS INFORMATION CONTAINED HEREIN IS PROPRIETARY TO SPELLMAN HIGH VOLTAGE ELECTRONICS CORP. AND IS TO BE USED ONLY FOR THE PURPOSES INTENDED AND IS NOT TO BE REPRODUCED EITHER IN WHOLE OR PART WITHOUT THE EXPRESS WRITTEN PERMISSION OF SPELLMAN HIGH VOLTAGE ELECTRONICS CORP.

REVISIONS		APPROVED				
LTR	DESCRIPTION	DATE	MECH. DESIGN	PROJ. ENG.	QUALITY	MFG. ENG.
A	RELEASED PER EDR 4568	2/4/98	M.L.K.	J.P.	X.X.	L.B.
A1	REVISED PER ECN NO. 11917	10/2/98	X.L.	J.P.	X.X.	L.B.
B	REVISED PER ECN NO. 12564	2/14/99	X.L.	J.P.	X.X.	L.B.

DESCRIPTION OF HOLES		
SYM	DESCRIPTION	QTY

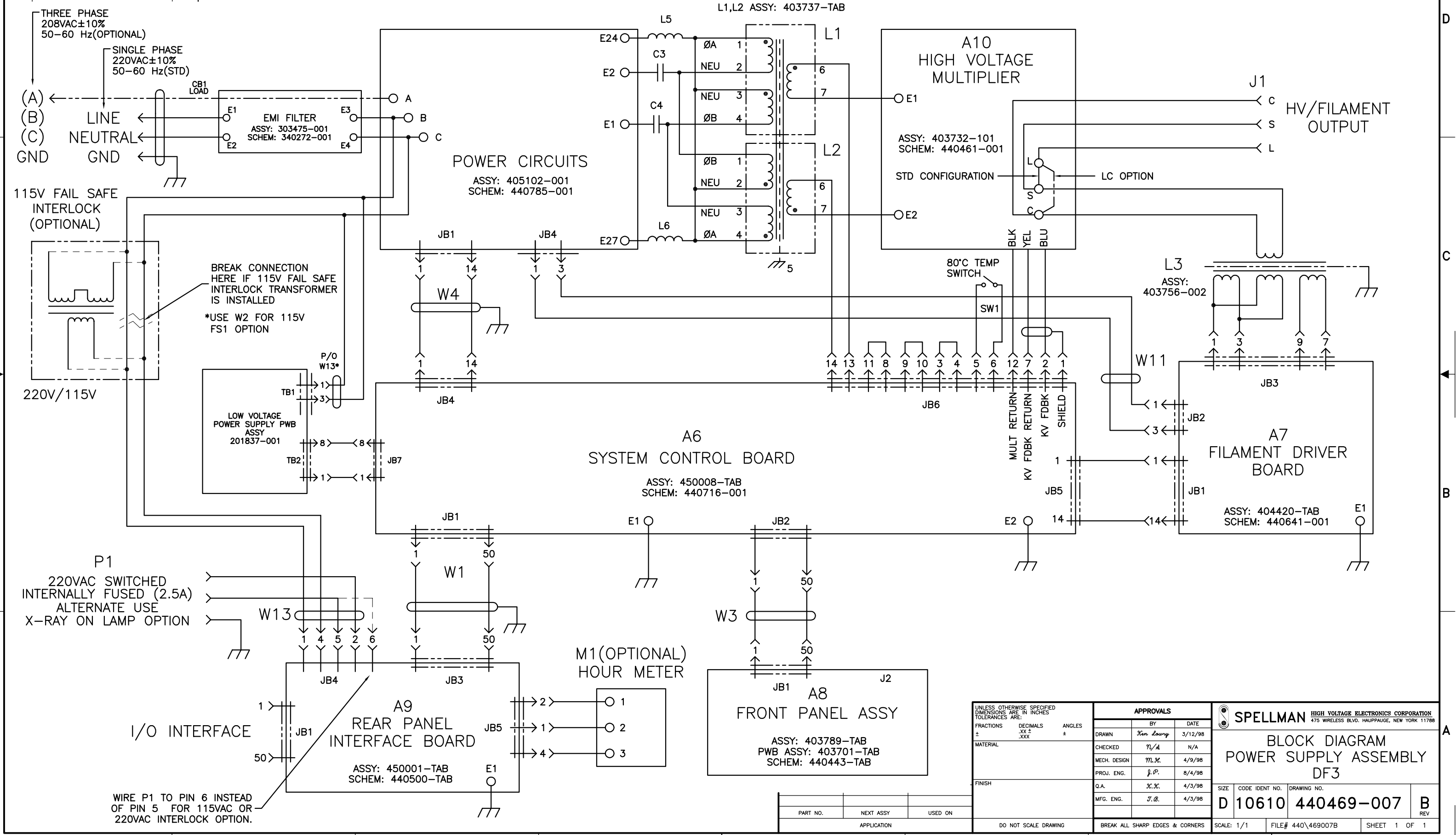

UNLESS OTHERWISE SPECIFIED DIMENSIONS ARE IN INCHES TOLERANCES ARE:			APPROVALS			 475 WIRELESS BLVD. HAUPPAUGE, NEW YORK 11788
FRACTIONS	DECIMALS	ANGLES	BY	DATE		
±	.XX ±	±	John Lowry	3/12/98	DRAWN	BLOCK DIAGRAM POWER SUPPLY ASSEMBLY DF3
	.XXX				CHECKED	
					MECH. DESIGN	
					PROJ. ENG.	
					MFG. ENG.	
FINISH			Q.A.	4/3/98		SIZE CODE IDENT NO. DRAWING NO. D 10610 440469-007 B
PART NO. NEXT ASSY USED ON APPLICATION			MFG. ENG.	4/3/98		
DO NOT SCALE DRAWING			BREAK ALL SHARP EDGES & CORNERS		SCALE: 1/1	FILE# 440\469007B SHEET 1 OF 1

THIS INFORMATION CONTAINED HEREIN IS PROPRIETARY TO SPELLMAN HIGH VOLTAGE ELECTRONICS CORP. AND IS TO BE USED ONLY FOR THE PURPOSES INTENDED AND IS NOT TO BE REPRODUCED EITHER IN WHOLE OR PART WITHOUT THE EXPRESS WRITTEN PERMISSION OF SPELLMAN HIGH VOLTAGE ELECTRONICS CORP.

REVISIONS		APPROVED				
LTR	DESCRIPTION	DATE	MECH. DESIGN	PROJ. ENG.	QUALITY	MFG. ENG.
A	RELEASED PER EDR 4568	2/4/98	M.L.	J.P.	X.X.	L.B.
A1	REVISED PER ECN NO. 11917	10/2/98	X.L.	J.P.	X.X.	L.B.
B	REVISED PER ECN NO. 12564	7/14/99	X.L.	J.P.	X.X.	L.B.

DESCRIPTION OF HOLES		
SYM	DESCRIPTION	QTY

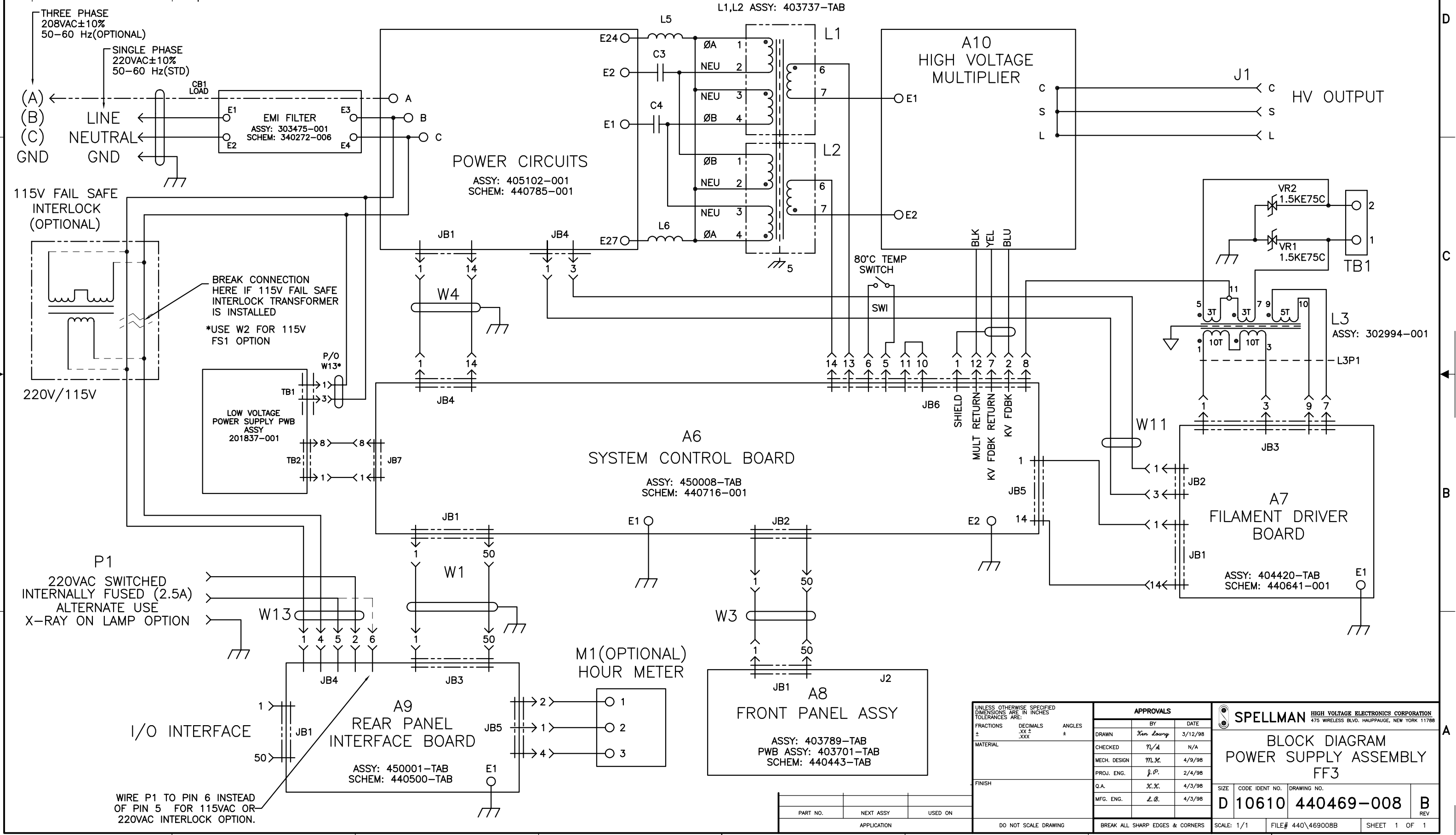

UNLESS OTHERWISE SPECIFIED DIMENSIONS ARE IN INCHES TOLERANCES ARE:			APPROVALS			SPELLMAN HIGH VOLTAGE ELECTRONICS CORPORATION 475 WIRELESS BLVD. HAUPPAUGE, NEW YORK 11788	
FRACTIONS	DECIMALS	ANGLES	BY	DATE			
±	.XX ±	±	Jan Lowry	3/12/98	DRAWN		
	.XXX				CHECKED		
					MECH. DESIGN		
					PROJ. ENG.		
					Q.A.		
					MFG. ENG.		
MATERIAL			FINISH			SIZE	
						CODE IDENT NO.	
						DRAWING NO.	
						D 10610 440469-008	
						SCALE: 1/1	
						FILE# 440\469008B	
						SHEET 1 OF 1	

PART NO.	NEXT ASSY	USED ON

WIRE P1 TO PIN 6 INSTEAD OF PIN 5 FOR 115VAC OR 220VAC INTERLOCK OPTION.

DO NOT SCALE DRAWING

BREAK ALL SHARP EDGES & CORNERS

THIS INFORMATION CONTAINED HEREIN IS PROPRIETARY TO SPELLMAN HIGH VOLTAGE ELECTRONICS CORP. AND IS TO BE USED ONLY FOR THE PURPOSES INTENDED AND IS NOT TO BE REPRODUCED EITHER IN WHOLE OR PART WITHOUT THE EXPRESS WRITTEN PERMISSION OF SPELLMAN HIGH VOLTAGE ELECTRONICS CORP.

REVISIONS		APPROVED			
LTR	DESCRIPTION	DATE	MECH. DESIGN	PROJ. ENG.	MFG. ENG.
A	RELEASED PER EDR 4674	9/29/98	X.X.	B.P.	X.X. L.B.
B	REVISED PER ECN NO. 12564	7/14/99	X.X.	B.P.	X.X. L.C.

DESCRIPTION OF HOLES		
SYM	DESCRIPTION	QTY

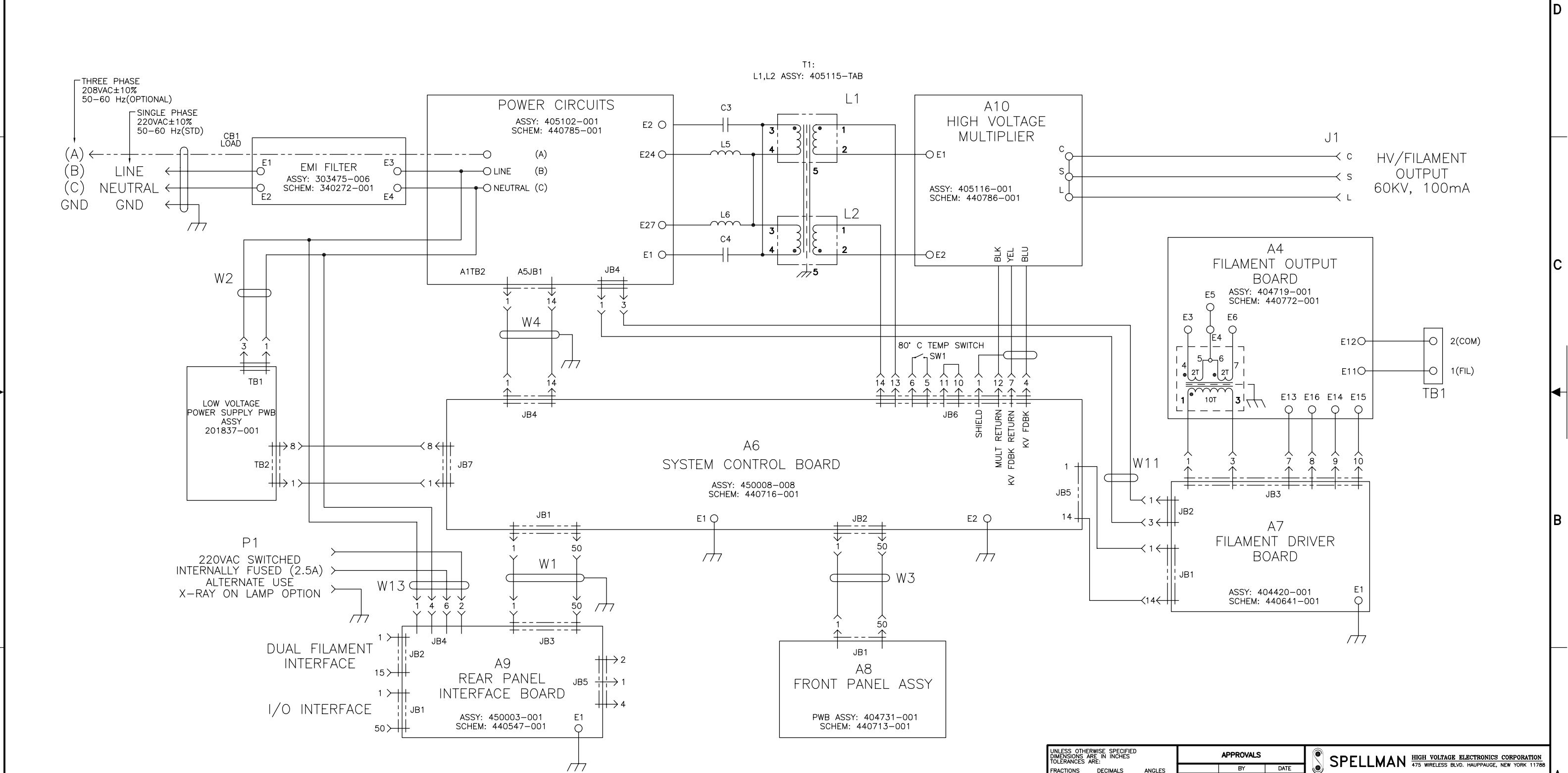

UNLESS OTHERWISE SPECIFIED DIMENSIONS ARE IN INCHES TOLERANCES ARE:			APPROVALS			SPELLMAN HIGH VOLTAGE ELECTRONICS CORPORATION 475 WIRELESS BLVD. HAUPPAUGE, NEW YORK 11788
FRACTIONS	DECIMALS	ANGLES	BY	DATE		
±	.XX ±	±	John Lowry	9/16/98	DRAWN	BLOCK DIAGRAM POWER SUPPLY ASSEMBLY X2695/X2749/X2870
±	.XXX	±			CHECKED	
					MECH. DESIGN	
					PROJ. ENG.	
					Q.A.	
					MFG. ENG.	SIZE CODE IDENT NO. DRAWING NO. D 10610 440469-009 B
440469-009		X2695				SCALE: 1/1 FILE# 440\469009B SHEET 1 OF 1
PART NO.	NEXT ASSY	USED ON				

440469-009		X2695
PART NO.	NEXT ASSY	USED ON

DO NOT SCALE DRAWING BREAK ALL SHARP EDGES & CORNERS

THIS INFORMATION CONTAINED HEREIN IS PROPRIETARY TO SPELLMAN HIGH VOLTAGE ELECTRONICS CORP. AND IS TO BE USED ONLY FOR THE PURPOSES INTENDED AND IS NOT TO BE REPRODUCED EITHER IN WHOLE OR PART WITHOUT THE EXPRESS WRITTEN PERMISSION OF SPELLMAN HIGH VOLTAGE ELECTRONICS CORP.

REVISIONS		APPROVED				
LTR	DESCRIPTION	DATE	MECH DESIGN	PROJ ENG	QUALITY	MFG ENG
1	PRELIMINARY RELEASE	N/A	N/A	N/A	N/A	N/A
A	RELEASED PER ECN 10327	3/31/99	X.L.	D.P.	X.X.	L.S.

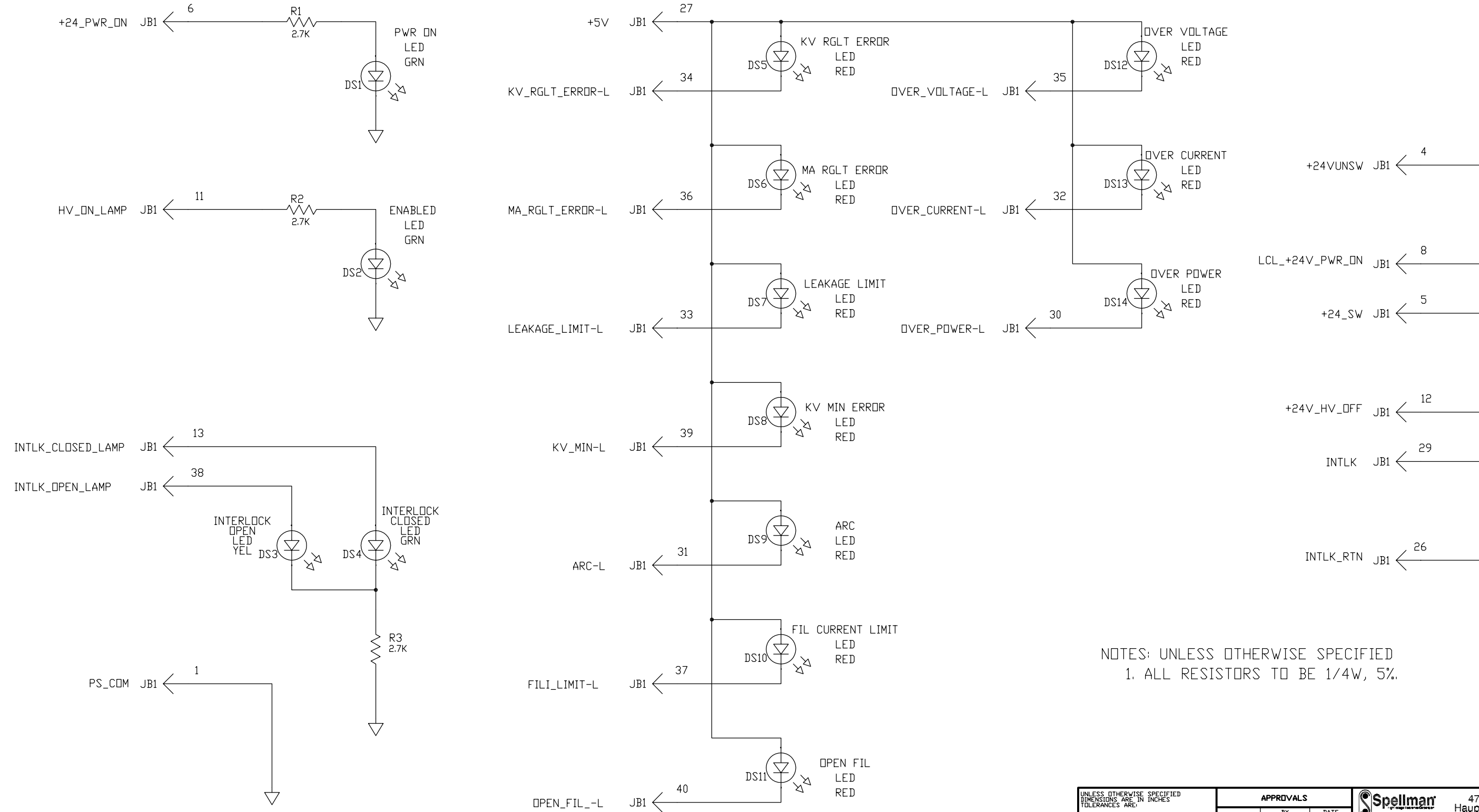

NOTES: UNLESS OTHERWISE SPECIFIED
1. ALL RESISTORS TO BE 1/4W, 5%.

440713-001	-	X2545
PART NO.	NEXT ASSY	USED ON
APPLICATION		

UNLESS OTHERWISE SPECIFIED DIMENSIONS ARE IN INCHES TOLERANCES ARE:		
FRACTIONS	DECIMALS	ANGLES
±	.XX ±	±
	.XXX	

APPROVALS		
DRAWN	BY	DATE
CHECKED	X.L.	10/28/96
MECH. DESIGN	N/A	N/A
PROJ. ENG.	D.P.	3/21/97
Q.A.	X.X.	3/31/97
MFG. ENG.	L.S.	3/31/97

Spellman 475 Wireless Boulevard
Hauppauge, New York 11788

**SCHEMATIC DIAGRAM
FRONT PANEL BOARD**
X2545/X2695/X2749/X2870

SIZE	CODE	IDENT NO.	DRAWING NO.
D	10610	440713-001	A

DO NOT SCALE DRAWING BREAK ALL SHARP EDGES & CORNERS SCALE: NONE FILE# SHEET 1 OF 1

THIS INFORMATION CONTAINED HEREIN IS PROPRIETARY TO SPELLMAN HIGH VOLTAGE ELECTRONICS CORP. AND IS TO BE USED ONLY FOR THE PURPOSES INTENDED AND IS NOT TO BE REPRODUCED EITHER IN WHOLE OR PART WITHOUT THE EXPRESS WRITTEN PERMISSION OF SPELLMAN HIGH VOLTAGE ELECTRONICS CORP.

DESCRIPTION OF HOLES
HOLE SIZES APPLY TO INSTALLATION SIDE OF HOUSING, IF APPLICABLE

SYM	DESCRIPTION	QTY
-----	-------------	-----

D

C

B

A

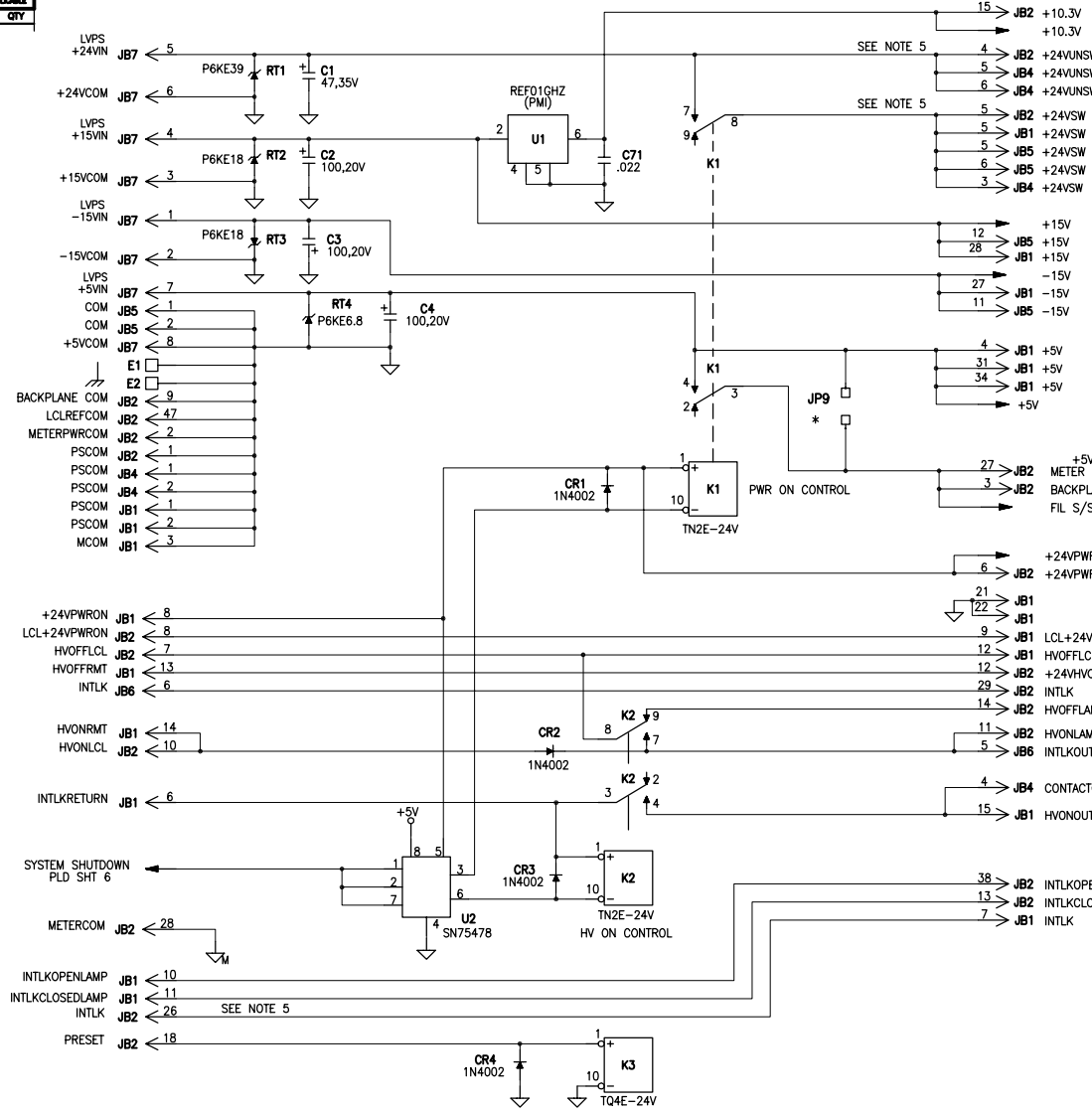

REVISIONS				APPROVED		
LTR	DESCRIPTION	DATE	DESIGN	PROF	QUALITY	ENG
A	REVISED AND RELEASED PER ECN 10424	5/13/97	JMK	SP	JMP	JFB
B	REVISED PER ECN 11219	2/16/98	JMK	SP	JMK	JFB
B1	REVISED PER ECN 11321	3/15/98	JMK	SP	JMK	JFB
B2	REVISED PER ECN 11878	9/16/98	JMK	SP	JMK	JFB
B3	REVISED PER ECN 12164	1/15/99	JMK	SP	JMK	JFB
C	REVISED PER ECN 12637	8/25/99	JMK	JK	JMK	JFB
C1	REVISED PER ECN 13009	2/28/00	JMK	JK	JMK	JFB
C2	REVISED PER ECN 14893	3/1/02	SK	JK	SK	JFB
C3	REVISED PER ECN 15081	5/9/02	SK	JK	SK	JFB
D	REVISED PER ECN 15101	6/28/02	SK	JK	SK	JFB
E	REVISED PER ECN 15396	11/11/02	SK	JK	SK	JFB
E1	REVISED PER ECN 16201	9/3/03	JVA	JFB	JMK	JFB
E2	REVISED PER ECN 18095	8/15/06	JVA	JFB	JMK	JFB
F	REVISED PER ECN 19049	6/23/06	JVA	JFB	JFB	JFB
G	REVISED PER ECN 19682	12/9/06	JVA	JFB	JFB	JFB
H	REVISED PER ECN NO. 20380	6/4/07	JVA	JFB	JFB	JFB

TABLE II (JUMPERS -010 ONLY)

FROM	TO
JB2-4	JB2-8
JB2-5	JB2-12
JB2-26	JB2-29

- NOTES
- UNLESS OTHERWISE SPECIFIED: RESISTORS ARE IN OHMS, 1/4W. 1/8W RESISTORS ARE RN, 1%. 1/10W RESISTORS ARE RN, 0.1%. CAPACITORS ARE IN MICROFARADS.
 - ALL DIODES FDH333 UNLESS OTHERWISE STATED.
 - ALL CAPS CK05 STYLE UNLESS OTHERWISE STATED.
 - * INDICATES TABULATED COMPONENTS SEE TABLE I SHEET 7.
 - FOR JUMPER REQUIREMENTS ON -010 ASSEMBLY SEE TABLE II.

UNLESS OTHERWISE SPECIFIED DIMENSIONS ARE IN INCHES [mm]

FORMALS	BY	DATE
ASST		
MATERIAL		
FINISH		

APPROVALS

CHECKED	BY	DATE
MECH. DESIGN		
PROJ. ENG.		
Q.A.		
MFG. ENG.		

Spellman 475 Wireless Boulevard
Hauppauge, New York 11788

SCHEMATIC DIAGRAM
SYSTEM CONTROL BOARD
DF3/FF3

SIZE: **D 10610** CODE IDENT NO.: **440716-001** DRAWING NO.: **H**

DO NOT SCALE DRAWING BREAK ALL SHARP EDGES & CORNERS SCALE: NONE FILE# SHEET 1 OF 7

THIS INFORMATION CONTAINED HEREIN IS PROPRIETARY TO SPELLMAN HIGH VOLTAGE ELECTRONICS CORP. AND IS TO BE USED ONLY FOR THE PURPOSES INTENDED AND IS NOT TO BE REPRODUCED EITHER IN WHOLE OR PART WITHOUT THE EXPRESS WRITTEN PERMISSION OF SPELLMAN HIGH VOLTAGE ELECTRONICS CORP.

8 7 6 5 4 3 2 1

D

C

B

A

D

C

B

A

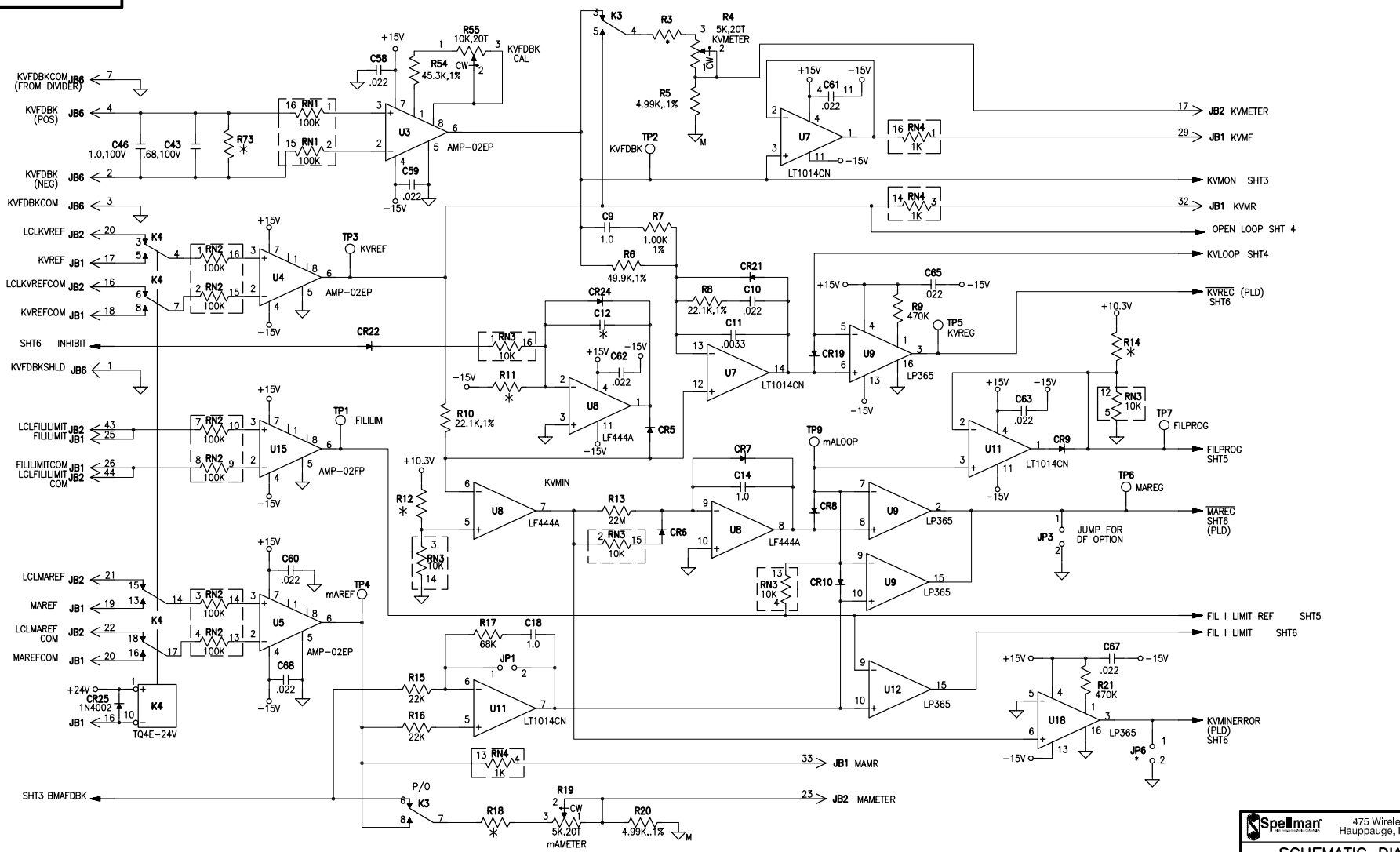

Spellman 475 Wireless Boulevard
Hauppauge, New York 11788

SCHEMATIC DIAGRAM
SYSTEM CONTROL BOARD
DF3/FF3

SIZE	CODE IDENT NO.	DRAWING NO.	REV
D	10610	440716-001	H
SCALE: NONE	FILE#	SHEET 2 OF 7	

8 7 6 5 4 3 2 1

THIS INFORMATION CONTAINED HEREIN IS PROPRIETARY TO SPELLMAN HIGH VOLTAGE ELECTRONICS CORP. AND IS TO BE USED ONLY FOR THE PURPOSES INTENDED AND IS NOT TO BE REPRODUCED EITHER IN WHOLE OR PART WITHOUT THE EXPRESS WRITTEN PERMISSION OF SPELLMAN HIGH VOLTAGE ELECTRONICS CORP.

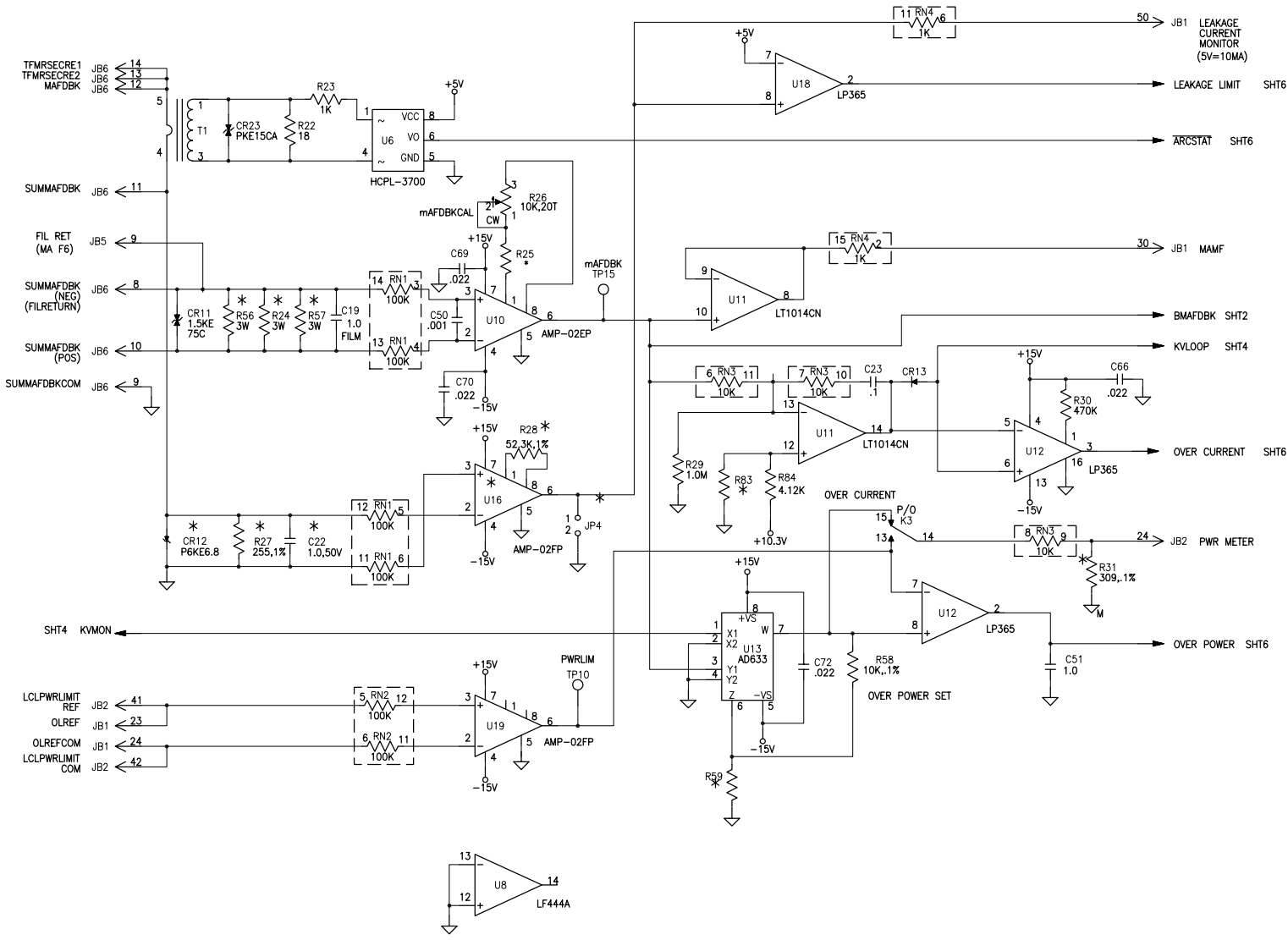

NOTE:
FOR 4KW OPTION R31=417.1K

		475 Wireless Boulevard Hauppauge, New York 11788	
SCHEMATIC DIAGRAM SYSTEM CONTROL BOARD DF3/FF3			
SIZE	CODE IDENT NO.	DRAWING NO.	REV
D	10610	440716-001	H
SCALE: NONE	FILE#	SHEET 3 OF 7	

THIS INFORMATION CONTAINED HEREIN IS PROPRIETARY TO SPELLMAN HIGH VOLTAGE ELECTRONICS CORP. AND IS TO BE USED ONLY FOR THE PURPOSES INTENDED AND IS NOT TO BE REPRODUCED EITHER IN WHOLE OR PART WITHOUT THE EXPRESS WRITTEN PERMISSION OF SPELLMAN HIGH VOLTAGE ELECTRONICS CORP.

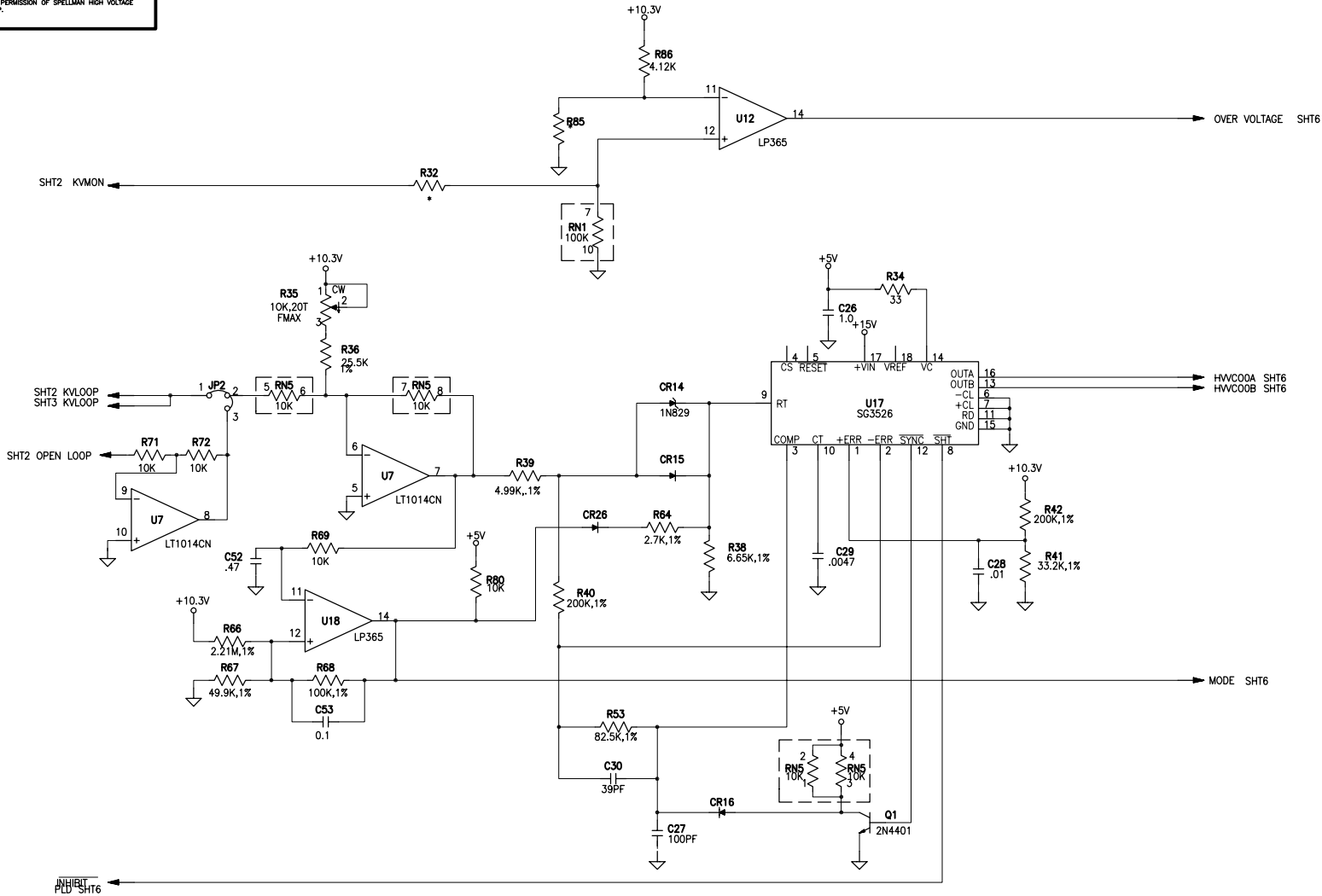

Spellman 475 Wireless Boulevard
Hauppauge, New York 11788

SCHEMATIC DIAGRAM
SYSTEM CONTROL BOARD
DF3/FF3

SIZE	CODE IDENT NO.	DRAWING NO.	H
D	10610	440716-001	REV
SCALE: NONE	FILE#	SHEET 4 OF 7	

THIS INFORMATION CONTAINED HEREIN IS PROPRIETARY TO SPELLMAN HIGH VOLTAGE ELECTRONICS CORP. AND IS TO BE USED ONLY FOR THE PURPOSES INTENDED AND IS NOT TO BE REPRODUCED EITHER IN WHOLE OR PART WITHOUT THE EXPRESS WRITTEN PERMISSION OF SPELLMAN HIGH VOLTAGE ELECTRONICS CORP.

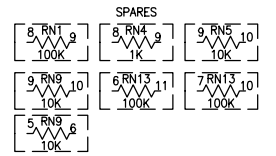
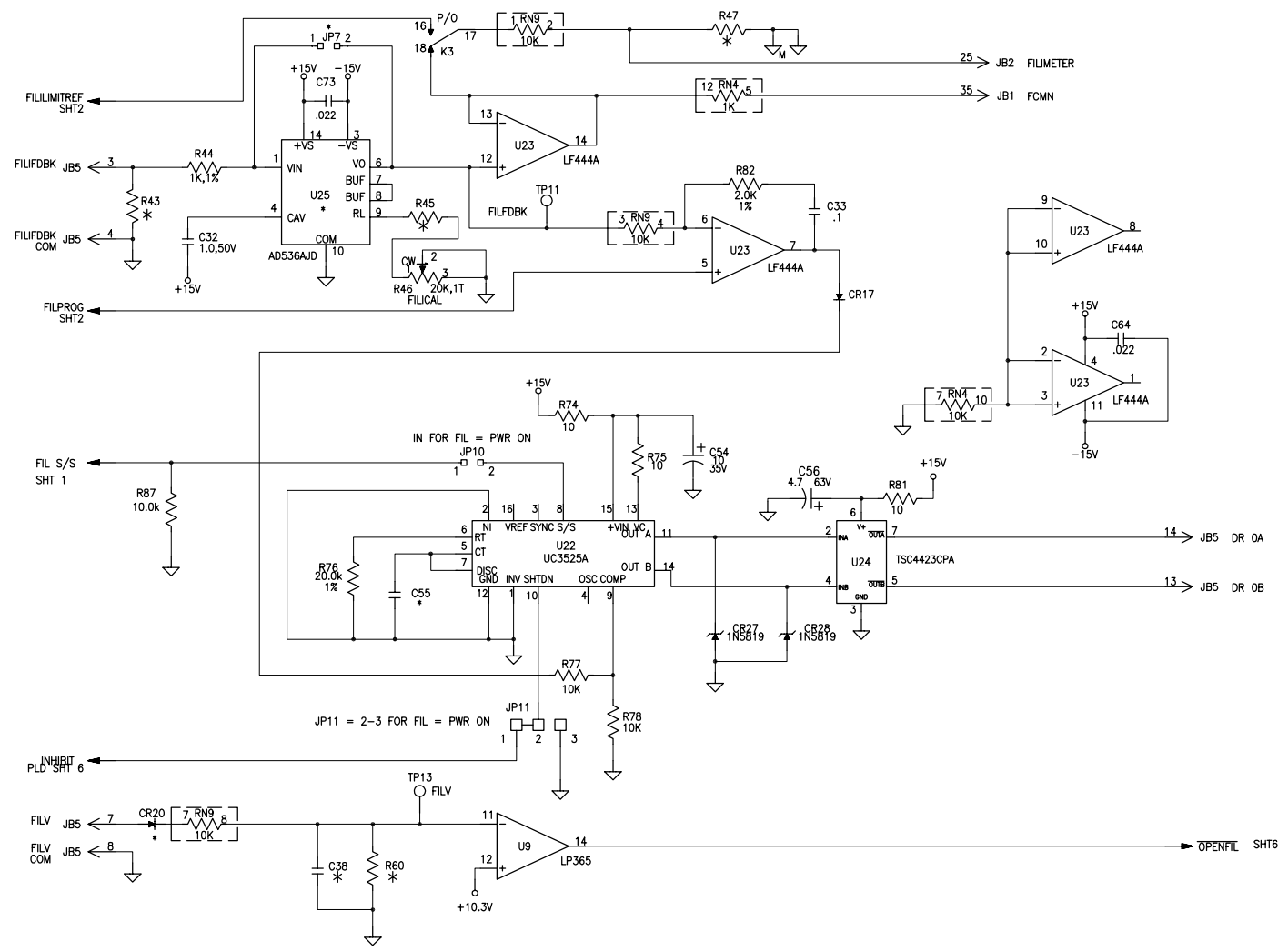

- 19 → JB2 SPARE
- 45 → JB2 SPARE
- 46 → JB2 SPARE
- 50 → JB2 SPARE
- 7 → JB4 SPARE
- 11 → JB4 SPARE
- 9 → JB5 SPARE
- 11 → JB5 SPARE
- 12 → JB5 SPARE

		475 Wireless Boulevard Hauppauge, New York 11788	
SCHEMATIC DIAGRAM SYSTEM CONTROL BOARD DF3/FF3			
SIZE	CODE IDENT NO.	DRAWING NO.	H REV
D	10610	440716-001	
SCALE: NONE	FILE#	SHEET 5 OF 7	

THIS INFORMATION CONTAINED HEREIN IS PROPRIETARY TO SPELLMAN HIGH VOLTAGE ELECTRONICS CORP. AND IS TO BE USED ONLY FOR THE PURPOSES INTENDED AND IS NOT TO BE REPRODUCED EITHER IN WHOLE OR PART WITHOUT THE EXPRESS WRITTEN PERMISSION OF SPELLMAN HIGH VOLTAGE ELECTRONICS CORP.

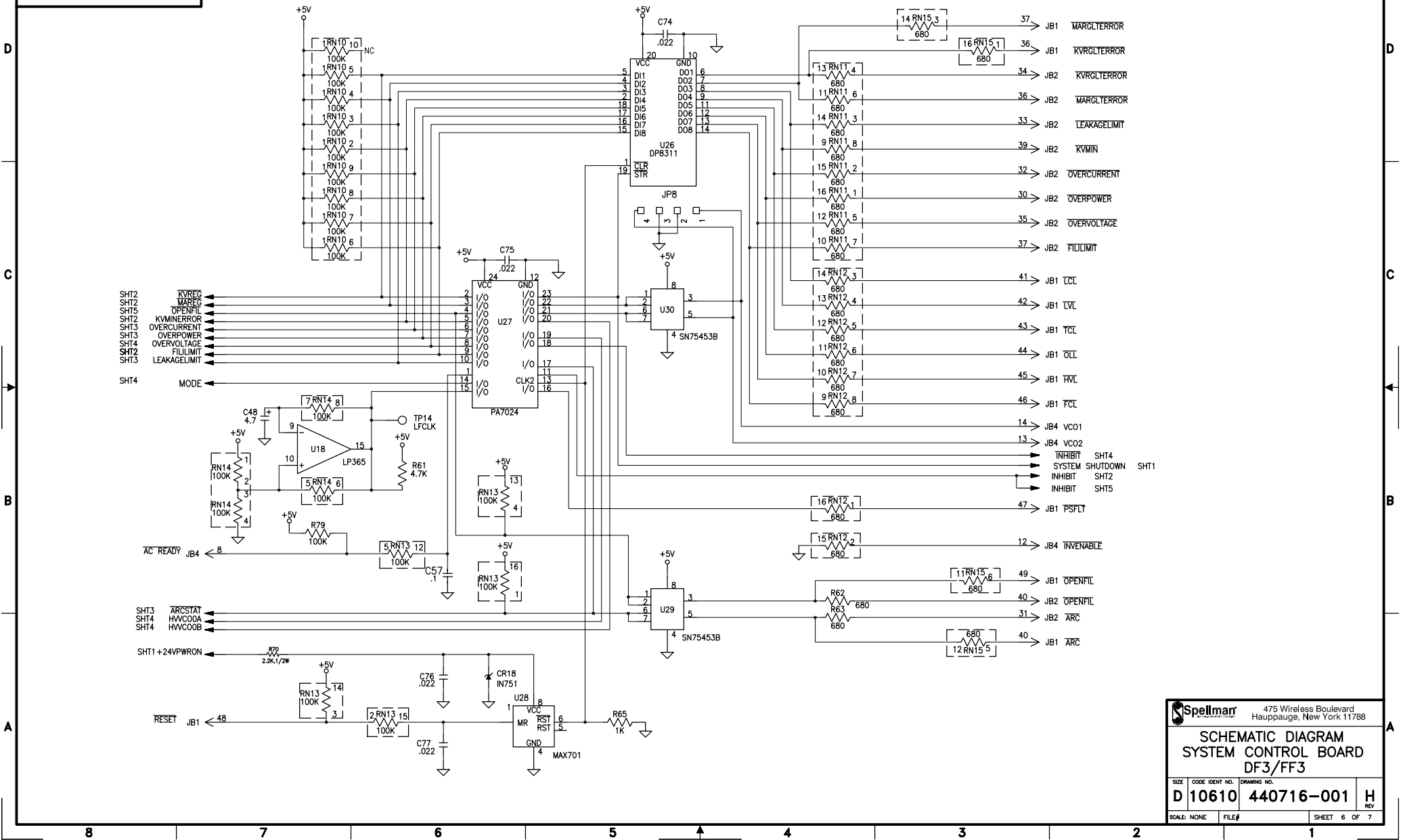

Spellman 475 Wireless Boulevard
Hauppauge, New York 11788

SCHEMATIC DIAGRAM
SYSTEM CONTROL BOARD
DF3/FF3

SIZE	CODE IDENT NO.	DRAWING NO.	REV
D	10610	440716-001	H
SCALE: NONE	FILE#	SHEET 6 OF 7	

THIS INFORMATION CONTAINED HEREIN IS PROPRIETARY TO SPELLMAN HIGH VOLTAGE ELECTRONICS CORP. AND IS TO BE USED ONLY FOR THE PURPOSES INTENDED AND IS NOT TO BE REPRODUCED EITHER IN WHOLE OR PART WITHOUT THE EXPRESS WRITTEN PERMISSION OF SPELLMAN HIGH VOLTAGE ELECTRONICS CORP.

TABLE I

ASSY DASH NO. 450008-XXX	PRODUCT DESIGNATOR	CR12	CR20	C12	C22	C38	C55	JP4	JP6	JP7	JP9	R3	R12	R18	R24	R25	R27	R28	R31	R32	R43	R45	R47	R56	R57	R59	R80	R73	R76	U16	U25	R83	R85	R11	R14	
-001	X2545	IN	0 OHM	1.0	IN	.1	.001	OUT	OUT	IN	IN	63.4K 1%	221K 1%	42.2K 1%	45.3K 1%	IN	IN	309 0.1%	5.36K 1%	OUT	OUT	1.4K 1%	150 1%	150 1%	13.3K 1%	OUT	OUT	20.0K 1%	IN	OUT	OUT	OUT	22M	49.9K		
-002	DF3/80mA	OUT	IN	1.0	OUT	.1	.001	IN	OUT	OUT	OUT	75K 1%	68.1K 1%	54.9K 1%	125 1%	45.3K 1%	OUT	OUT	309 0.1%	6.04K 0.1%	220 5%	69.8K 1%	536 1%	125 1%	OUT	6.04K 0.1%	19.1K 1%	OUT	16.9K 1%	OUT	IN	OUT	OUT	22M	49.9K	
	X2803	OUT	IN	4.7	OUT	.1	.001	IN	OUT	OUT	OUT	75K 1%	68.1K 1%	54.9K 1%	125 1%	45.3K 1%	OUT	OUT	309 0.1%	6.04K 0.1%	220 5%	69.8K 1%	536 1%	125 1%	OUT	6.04K 0.1%	19.1K 1%	OUT	16.9K 1%	OUT	IN	OUT	OUT	10M	42.3K	
-003	DF3/4KW	OUT	IN	1.0	OUT	.1	.001	IN	OUT	OUT	OUT	75K 1%	68.1K 1%	54.9K 1%	125 1%	45.3K 1%	OUT	OUT	417 0.1%	6.04K 0.1%	220 5%	69.8K 1%	536 1%	125 1%	OUT	2.0K 1%	19.1K 0.1%	OUT	16.9K 1%	OUT	IN	OUT	OUT	22M	49.9K	
-004	FF3/100mA	IN	IN	1.0	IN	.1	.0047	OUT	OUT	OUT	OUT	75K 1%	68.1K 1%	42.2K 1%	150 1%	45.3K 1%	IN	IN	309 0.1%	1.5K 1%	68 1%	127K 1%	1.4K 1%	150 1%	150 1%	10.0K 0.1%	28.4K 1%	OUT	20.0K 1%	IN	OUT	OUT	OUT	22M	49.9K	
-005	X2069	OUT	IN	1.0	OUT	.047	.0056	IN	IN	OUT	OUT	17.4K 1%	1M 1%	18.7K 1%	68 5%	32.4K 1%	OUT	OUT	309 0.1%	1.5K 1%	27 5%	499K 1%	1.10K 1%	68 5%	68 5%	2.8K 1%	42.2K 1%	OUT	20.0K 1%	OUT	OUT	OUT	OUT	22M	49.9K	
-006	FF4	IN	IN	1.0	IN	.33	.0047	OUT	OUT	OUT	OUT	75K 1%	68.1K 1%	25.5K 1%	100 1%	45.3K 1%	IN	IN	417 0.1%	1.5K 1%	68 5%	169K 1%	1.4K 1%	100 1%	100 1%	12.4K 1%	40.2K 1%	59.0K 1%	20.0K 1%	IN	OUT	OUT	OUT	22M	49.9K	
-008	X2695	IN	0 OHM	1.0	IN	.1	.001	OUT	OUT	IN	IN	63.4K 1%	221K 1%	34.8K 1%	150 1%	71.5K 1%	IN	IN	365 1%	5.36K 1%	OUT	OUT	1.4K 1%	150 1%	150 1%	13.3K 1%	OUT	OUT	20.0K 1%	IN	OUT	OUT	OUT	22M	49.9K	
-009	X2749	IN	0 OHM	1.0	IN	.1	.001	OUT	OUT	IN	IN	63.4K 1%	221K 1%	17.4K 1%	100 1%	95.3K 1%	IN	IN	432 1%	5.36K 1%	OUT	OUT	1.4K 1%	100 1%	100 1%	23.2K 1%	OUT	OUT	20.0K 1%	IN	OUT	6.04K 0.1%	OUT	OUT	22M	49.9K
-010	X2899	OUT	IN	1.0	OUT	.1	.001	IN	OUT	OUT	OUT	75K 1%	68.1K 1%	54.9K 1%	125 1%	45.3K 1%	OUT	OUT	417 0.1%	6.04K 0.1%	220 5%	69.8K 1%	536 1%	125 1%	OUT	2.0K 1%	19.1K 0.1%	OUT	16.9K 1%	OUT	IN	OUT	OUT	22M	49.9K	

Spellmar 475 Wireless Boulevard
Hauppauge, New York 11788

**SCHEMATIC DIAGRAM
SYSTEM CONTROL BOARD
DF3/FF3**

SIZE	CODE IDENT NO.	DRAWING NO.	H REV
D	10610	440716-001	H
SCALE: NONE	FILE#	SHEET 7 OF 7	

THIS INFORMATION CONTAINED HEREIN IS PROPRIETARY TO SPELLMAN HIGH VOLTAGE ELECTRONICS CORP. AND IS TO BE USED ONLY FOR THE PURPOSES INTENDED AND IS NOT TO BE REPRODUCED EITHER IN WHOLE OR PART WITHOUT THE EXPRESS WRITTEN PERMISSION OF SPELLMAN HIGH VOLTAGE ELECTRONICS CORP.

REVISIONS		APPROVED				
LTR	DESCRIPTION	DATE	MECH. DESIGN	PROJ. ENG.	QUALITY	HF/ENG.
1	PRELIMINARY RELEASE	N/A	N/A	N/A	N/A	N/A
A	RELEASED PER ECN 10424	5/13/97	M.H.	D.P.	M.P.	L.B.
A1	REVISED PER ECN 11321	3/13/98	X.X.	D.P.	X.X.	L.B.
A2	REVISED PER ECN 11778	9/11/98	X.X.	D.P.	X.X.	L.B.
B	REVISED PER ECN 12081	12/10/96	X.X.	D.P.	X.X.	L.B.

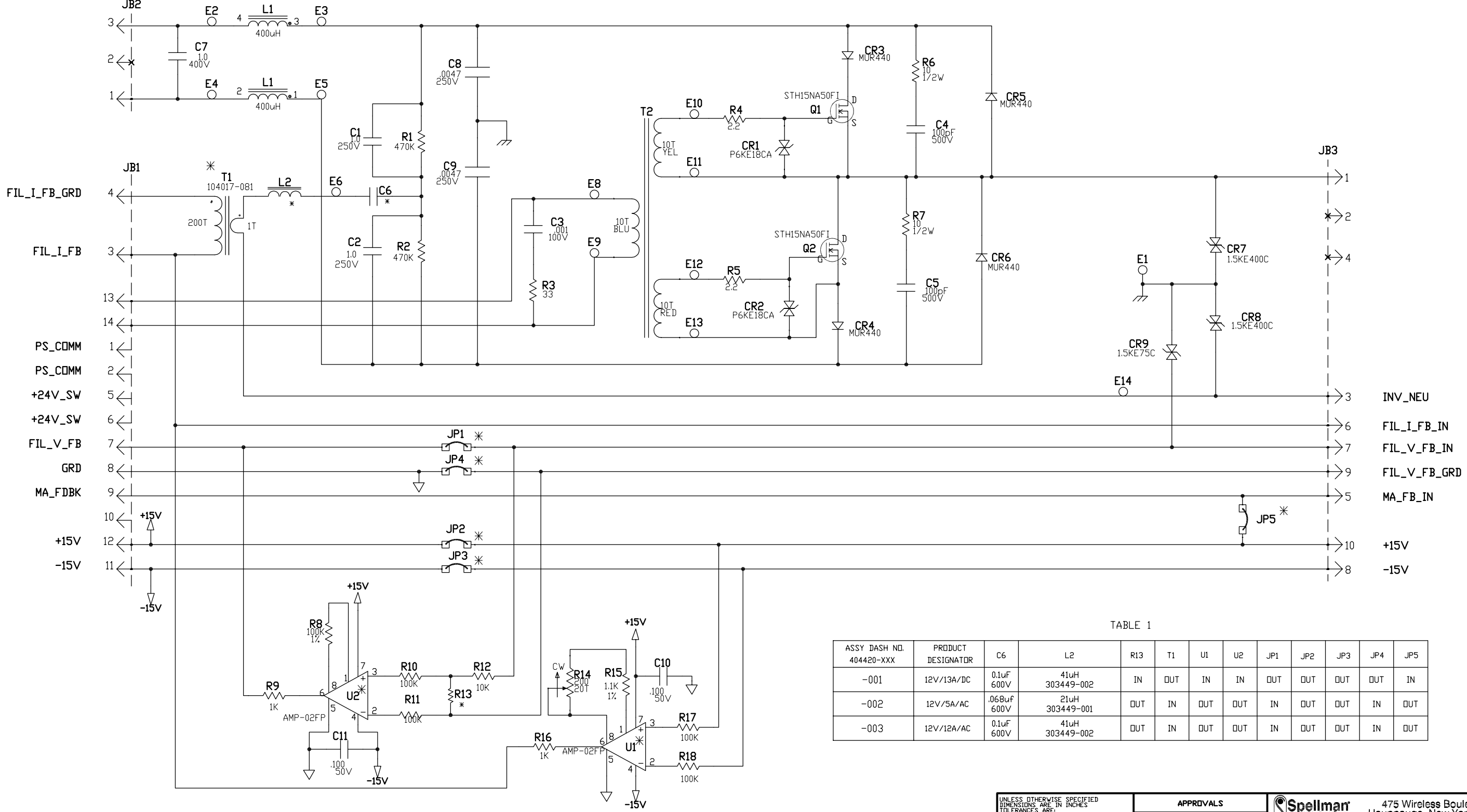

* SEE TABLE 1 FOR COMPONENT USAGE

TABLE 1

ASSY DASH NO. 404420-XXX	PRODUCT DESIGNATOR	C6	L2	R13	T1	U1	U2	JP1	JP2	JP3	JP4	JP5
-001	12V/13A/DC	0.1uF 600V	41uH 303449-002	IN	OUT	IN	IN	OUT	OUT	OUT	OUT	IN
-002	12V/5A/AC	.068uF 600V	21uH 303449-001	OUT	IN	OUT	OUT	IN	OUT	OUT	IN	OUT
-003	12V/12A/AC	0.1uF 600V	41uH 303449-002	OUT	IN	OUT	OUT	IN	OUT	OUT	IN	OUT

UNLESS OTHERWISE SPECIFIED DIMENSIONS ARE IN INCHES TOLERANCES ARE:		APPROVALS		Spellman 475 Wireless Boulevard Hauppauge, New York 11788	
FRACTIONS ±	DECIMALS .XX ± .XXX	ANGLES ±	BY J.B.	DATE 4/7/95	SCHEMATIC DIAGRAM FILAMENT FET INVERTER DF3
MATERIAL			CHECKED N/A	N/A	
FINISH			MECH. DESIGN N/A	N/A	
			PROJ. ENG. D.P.	5/16/97	
			Q.A. X.X.	5/16/97	
			MFG. ENG. L.B.	5/16/97	SIZE: D CODE IDENT NO.: 10610 DRAWING NO.: 440641-001 REV: B
440641-001		404420-001		df3	
PART NO.		NEXT ASSY		USED ON	
APPLICATION		DO NOT SCALE DRAWING		BREAK ALL SHARP EDGES & CORNERS	
SCALE: NONE		FILE#		SHEET 1 OF 1	

440641-001	404420-001	df3
PART NO.	NEXT ASSY	USED ON
APPLICATION		

THIS INFORMATION CONTAINED HEREIN IS PROPRIETARY TO SPELLMAN HIGH VOLTAGE ELECTRONICS CORP. AND IS TO BE USED ONLY FOR THE PURPOSES INTENDED AND IS NOT TO BE REPRODUCED EITHER IN WHOLE OR PART WITHOUT THE EXPRESS WRITTEN PERMISSION OF SPELLMAN HIGH VOLTAGE ELECTRONICS CORP.

DESCRIPTION OF HOLES

SOLE SIZES APPLY TO INSTALLATION SIDE OF HOLES, IF APPLICABLE

SYM	DESCRIPTION	QTY
-----	-------------	-----

REVISIONS				APPROVED		
LTR	DESCRIPTION	DATE	DESIGN	PROP. ENG.	QUALITY	REV.
1	PRELIMINARY RELEASE					
A	RELEASED PER ECN 10424	5/13/97	JL	SP	AL	AL
A1	REVISED PER ECN 10635	7/28/97	JL	SP	JL	AL
A2	REVISED PER ECN NO. 20728	9/9/97	JL	SP	SP	JL

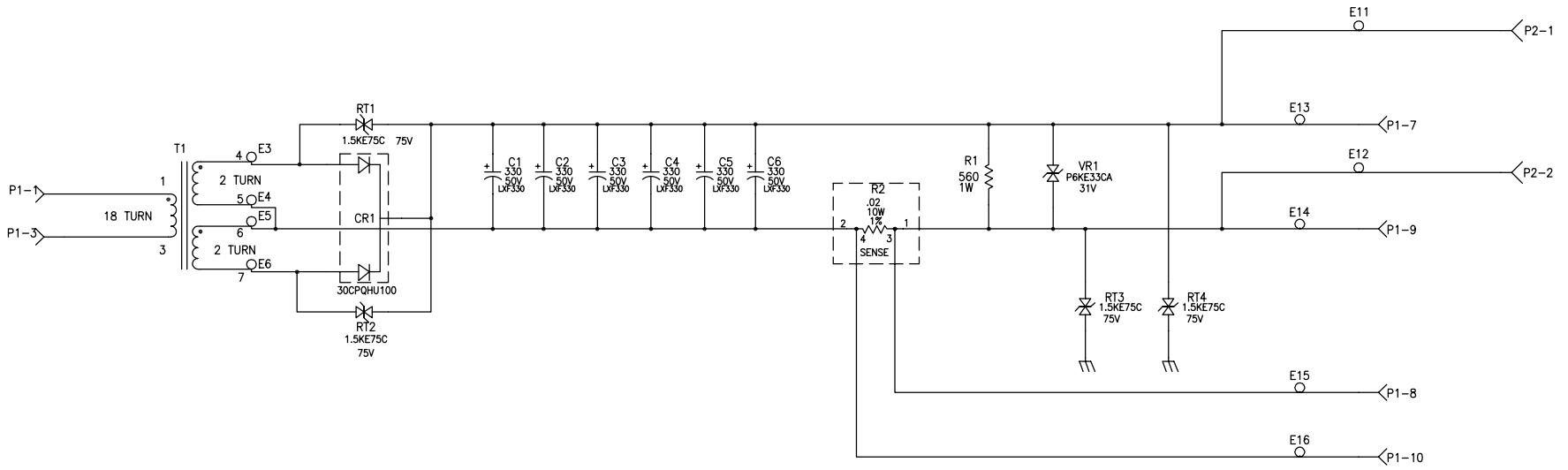

NOTES:
1. UNLESS OTHERWISE SPECIFIED:
RESISTORS ARE IN OHMS,
CAPACITORS ARE IN MICROFARADS

UNLESS OTHERWISE SPECIFIED DIMENSIONS ARE IN INCHES [mm] AND TOLERANCES ARE:		APPROVALS		Spellman 475 Wireless Boulevard Hauppauge, New York 11788	
ORIGINALS	(mm)	BY	DATE	SCHMATIC DIAGRAM 12A/12V DC FILAMENT FF3	D 10610 440772-001 A2 REV
.001	.005	DRWN	JL Ziemer 12/23/96		
.002	.010	CHECKED	JL Ziemer 12/23/96		
.005	.020	MECH. DESIGN	JL Ziemer 12/23/96		
.010	.050	PROJ. ENG.	SP Padilla 5/13/97		
FINISH		Q.A.	JL Padilla 5/16/97	SIZE	CODE IDENT NO.
		MFG. ENG.	JL Padilla 5/16/97	D	10610
DO NOT SCALE DRAWING		BREAK ALL SHARP EDGES & CORNERS		SCALE: NONE	THIRD ANGLE PROJECTION
				SHEET 1 OF 1	

THIS INFORMATION CONTAINED HEREIN IS PROPRIETARY TO SPELLMAN HIGH VOLTAGE ELECTRONICS CORP. AND IS TO BE USED ONLY FOR THE PURPOSES INTENDED AND IS NOT TO BE REPRODUCED EITHER IN WHOLE OR PART WITHOUT THE EXPRESS WRITTEN PERMISSION OF SPELLMAN HIGH VOLTAGE ELECTRONICS CORP.

DESCRIPTION OF HOLES
HOLE SIZES APPLY TO INSTALLATION SIZE OF HARDWARE, IF APPLICABLE

SYM	DESCRIPTION	QTY

LINE INPUT
SINGLE PHASE (3 PHASE)
220 (208) VAC +/-10%
50 -60 Hz

REVISIONS		DATE	DESIGN	APP'D	QUALITY	BY
A	RELEASED PER ECN 11896	10/2/98	JJC	SP	JJC	JJC
A1	REVISED PER ECN 12022	11/20/98	E.E.	SP	JJC	JJC
B	REVISED PER ECN 12274	3/18/99	J.C.	SP	J.C.	J.C.
C	REVISED PER ECN 12490	6/24/99	J.C.	SP	J.C.	J.C.
D	REVISED PER ECN NO. 19104	7/28/04	J.J.	SP	J.J.	J.J.

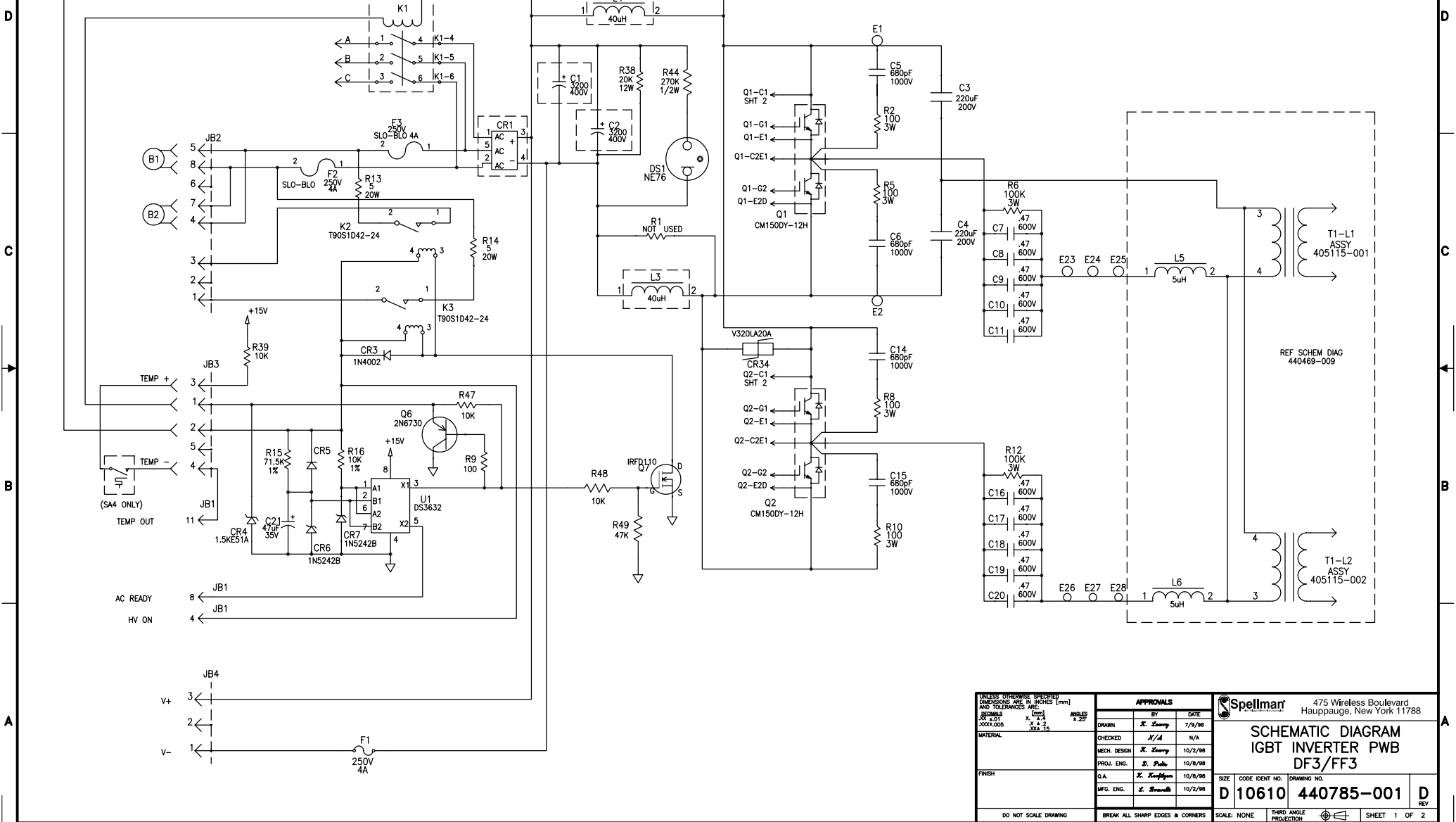

UNLESS OTHERWISE SPECIFIED
DIMENSIONS ARE IN INCHES [mm]
DIMENSIONS AND TOLERANCES ARE:
FRACTIONS DECIMALS (mm)
X .01 X .1 X .2 X .5 X 1.0 X 2.0 X 5.0 X 10.0 X 20.0 X 50.0 X 100.0 X 200.0 X 500.0 X 1000.0
MATERIAL FINISH

APPROVALS		DATE
DRAWN	J. Zeng	7/9/98
CHECKED	J. Zeng	7/9/98
MECH. DESIGN	J. Zeng	10/2/98
PROJ. ENG.	S. Palla	10/9/98
Q.A.	J. Zeng	10/9/98
MFG. ENG.	J. Zeng	10/2/98

Spellman 475 Wireless Boulevard
Hauppauge, New York 11788

SCHMATIC DIAGRAM
IGBT INVERTER PWB
DF3/FF3

SIZE: **D** CODE IDENT NO.: **10610** DRAWING NO.: **440785-001**

DO NOT SCALE DRAWING
BREAK ALL SHARP EDGES & CORNERS
SCALE: NONE
THIRD ANGLE PROJECTION
SHEET 1 OF 2

THIS INFORMATION CONTAINED HEREIN IS PROPRIETARY TO SPELLMAN HIGH VOLTAGE ELECTRONICS CORP. AND IS TO BE USED ONLY FOR THE PURPOSES INTENDED AND IS NOT TO BE REPRODUCED EITHER IN WHOLE OR PART WITHOUT THE EXPRESS WRITTEN PERMISSION OF SPELLMAN HIGH VOLTAGE ELECTRONICS CORP.

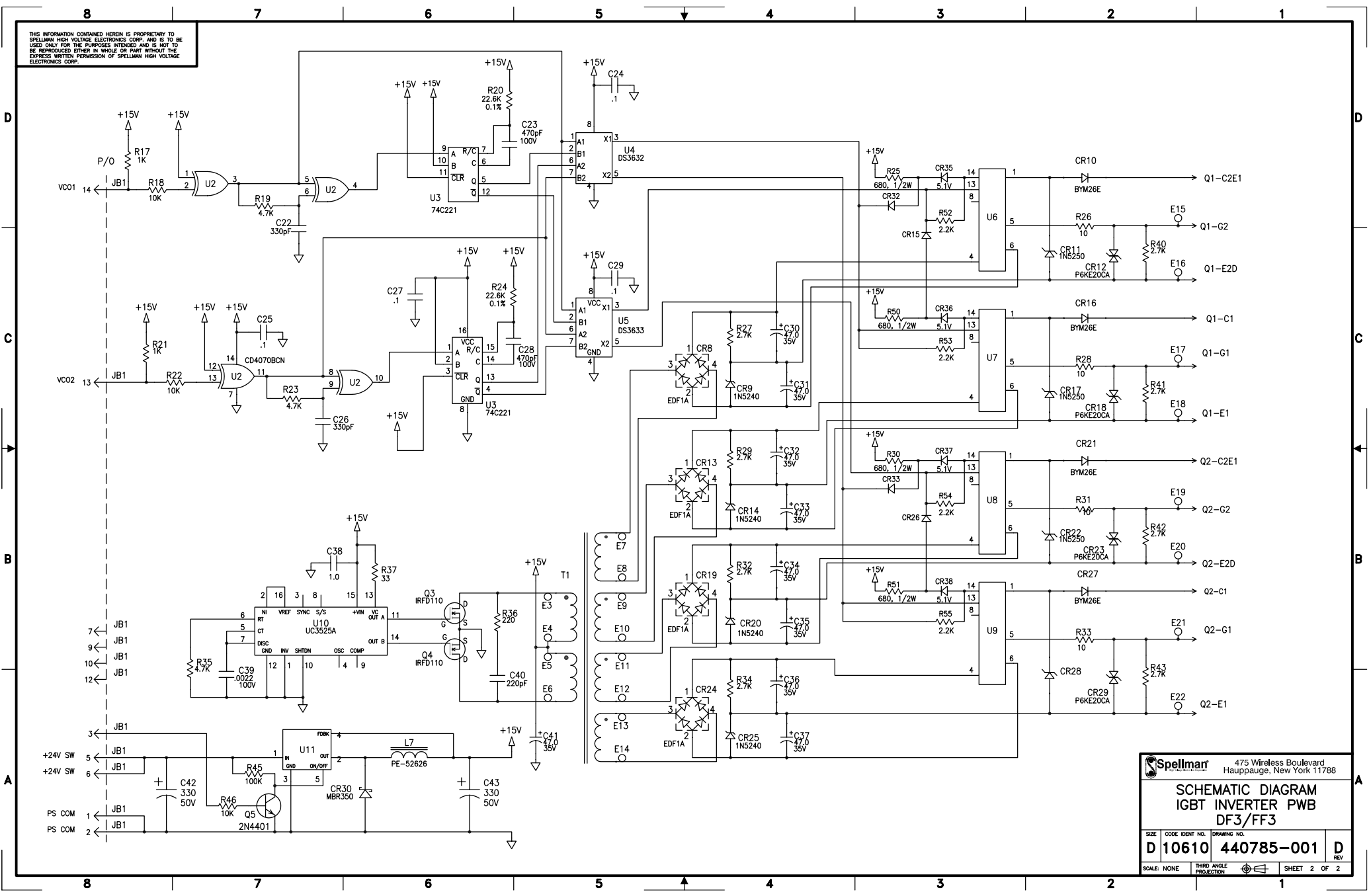

Spellman 475 Wireless Boulevard
Hauppauge, New York 11788

SCHMATIC DIAGRAM
IGBT INVERTER PWB
DF3/FF3

SIZE	CODE IDENT NO.	DRAWING NO.	REV
D	10610	440785-001	D

SCALE: NONE THIRD ANGLE PROJECTION SHEET 2 OF 2

THIS INFORMATION CONTAINED HEREIN IS PROPRIETARY TO SPELLMAN HIGH VOLTAGE ELECTRONICS CORP. AND IS TO BE USED ONLY FOR THE PURPOSES INTENDED AND IS NOT TO BE REPRODUCED EITHER IN WHOLE OR PART WITHOUT THE EXPRESS WRITTEN PERMISSION OF SPELLMAN HIGH VOLTAGE ELECTRONICS CORP.

DESCRIPTION OF HOLES

HOLE SIZES APPLY TO INSTALLATION SIDE OF HARDWARE, IF APPLICABLE

SYM	DESCRIPTION	QTY
-----	-------------	-----

REVISIONS				APPROVED		
LTR	DESCRIPTION	DATE	DESIGN	PROP	ENG	QUALITY
A	RELEASE PER EDR 3394	12/29/93	N/A	JSF	JCC	JSF
A1	REVISED PER ECN 8002	7/14/94	N/A	JSF	JCC	JSF
A2	REVISED PER ECN 10137	12/24/94	N/A	JSF	JCC	JSF
A3	REVISED PER ECN 11375	3/30/96	JCC	JSF	JCC	JSF
B	REVISED PER ECN 11936	9/21/96	N/A	JSF	JCC	JSF
B1	REVISED PER ECN 12086	12/4/96	JCC	JSF	JCC	JSF
C	REVISED PER ECN 12637	N/A	JCC	JSF	JCC	JSF
C1	REVISED PER ECN NO. 19682	12/9/96	N/A	JSF	JCC	JSF
C2	REVISED PER ECN NO. 20728	9/9/97	N/A	JSF	JCC	JSF
C3	REVISED PER ECN NO. 23336	8/28/09	N/A	JSF	JSF	JSF

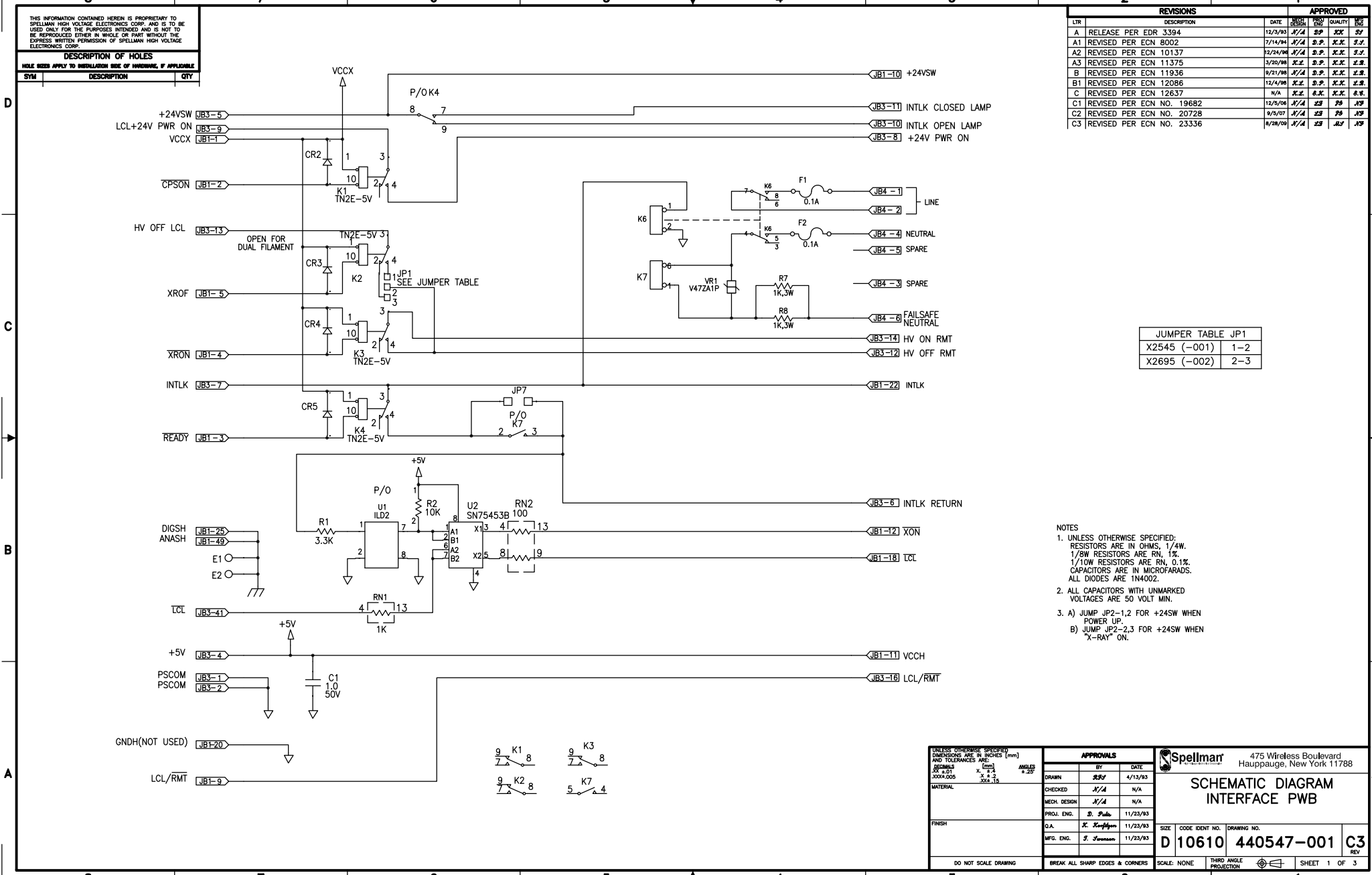

JUMPER TABLE JP1	
X2545 (-001)	1-2
X2695 (-002)	2-3

- NOTES
- UNLESS OTHERWISE SPECIFIED, RESISTORS ARE IN OHMS, 1/4W. 1/5W RESISTORS ARE RN, 1%. 1/10W RESISTORS ARE RN, 0.1%. CAPACITORS ARE IN MICROFARADS. ALL DIODES ARE 1N4002.
 - ALL CAPACITORS WITH UNMARKED VOLTAGES ARE 50 VOLT MIN.
 - A) JUMP JP2=1,2 FOR +24SW WHEN POWER UP.
B) JUMP JP2=2,3 FOR +24SW WHEN "X-RAY" ON.

UNLESS OTHERWISE SPECIFIED DIMENSIONS ARE IN INCHES [mm] AND TOLERANCES ARE:

APPROX	(mm)	ANGLES
±0.01	x, y, z	±25°
±0.005	x, y, z	±15°

APPROVALS		DATE
DRAWN	JSF	4/13/93
CHECKED	N/A	N/A
MECH. DESIGN	N/A	N/A
PROJ. ENG.	S. Pella	11/23/93
Q.A.	K. Koppelman	11/23/93
MFG. ENG.	J. Swanson	11/23/93

Spellmar 475 Wireless Boulevard
Hauppauge, New York 11788

**SCHMATIC DIAGRAM
INTERFACE PWB**

SIZE	CODE IDENT NO.	DRAWING NO.
D	10610	440547-001

C3

DO NOT SCALE DRAWING

BREAK ALL SHARP EDGES & CORNERS

SCALE: NONE

THIRD ANGLE PROJECTION

SHEET 1 OF 3

THIS INFORMATION CONTAINED HEREIN IS PROPRIETARY TO SPELLMAN HIGH VOLTAGE ELECTRONICS CORP. AND IS TO BE USED ONLY FOR THE PURPOSES INTENDED AND IS NOT TO BE REPRODUCED EITHER IN WHOLE OR PART WITHOUT THE EXPRESS WRITTEN PERMISSION OF SPELLMAN HIGH VOLTAGE ELECTRONICS CORP.

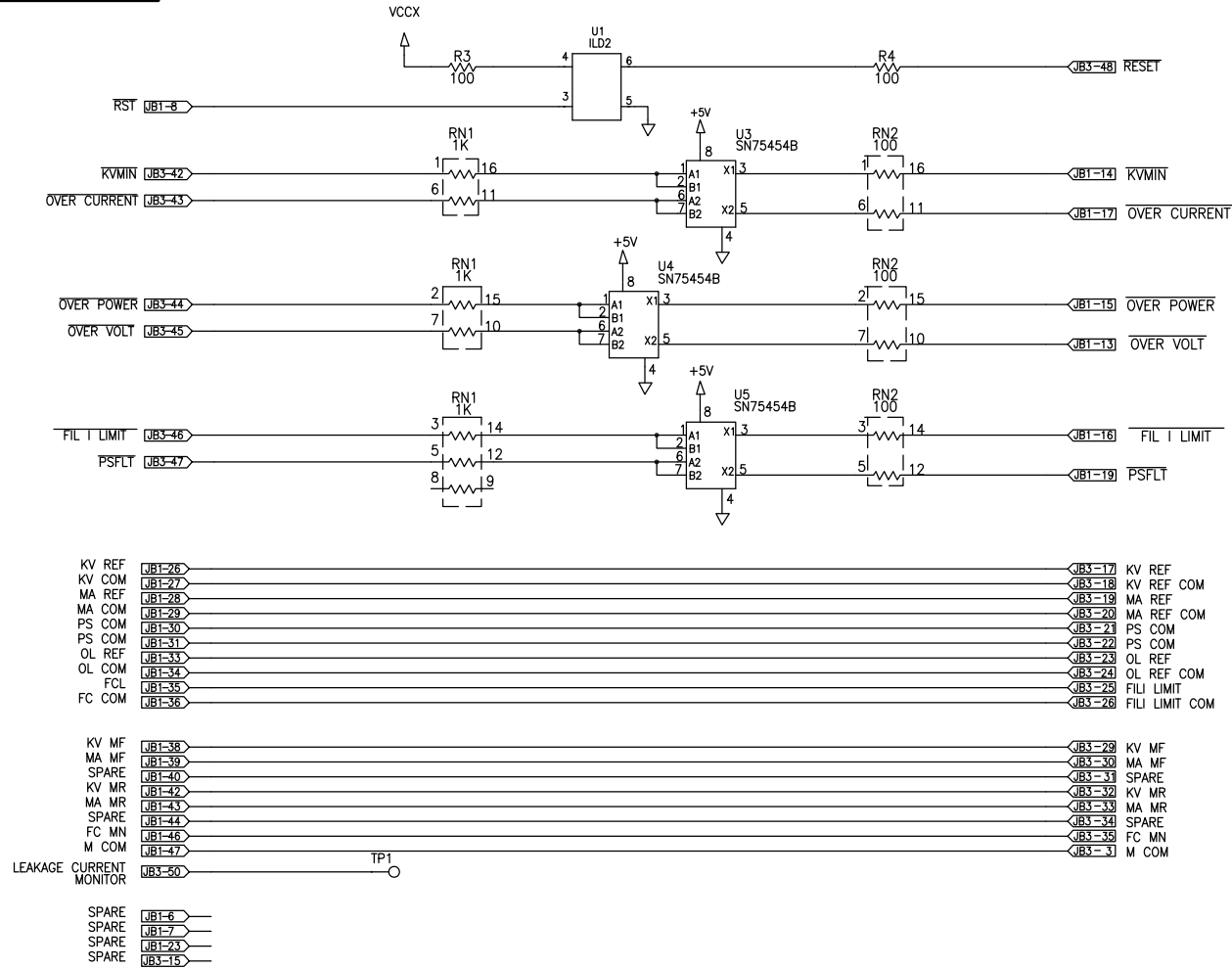

Spellman 475 Wireless Boulevard
Hauppauge, New York 11788

**SCHMATIC DIAGRAM
INTERFACE PWB**

SIZE	CODE IDENT NO.	DRAWING NO.	
D	10610	440547-001	C3
SCALE: NONE	THIRD ANGLE PROJECTION	SHEET 2 OF 3	REV

THIS INFORMATION CONTAINED HEREIN IS PROPRIETARY TO SPELLMAN HIGH VOLTAGE ELECTRONICS CORP. AND IS TO BE USED ONLY FOR THE PURPOSES INTENDED AND IS NOT TO BE REPRODUCED EITHER IN WHOLE OR PART WITHOUT THE EXPRESS WRITTEN PERMISSION OF SPELLMAN HIGH VOLTAGE ELECTRONICS CORP.

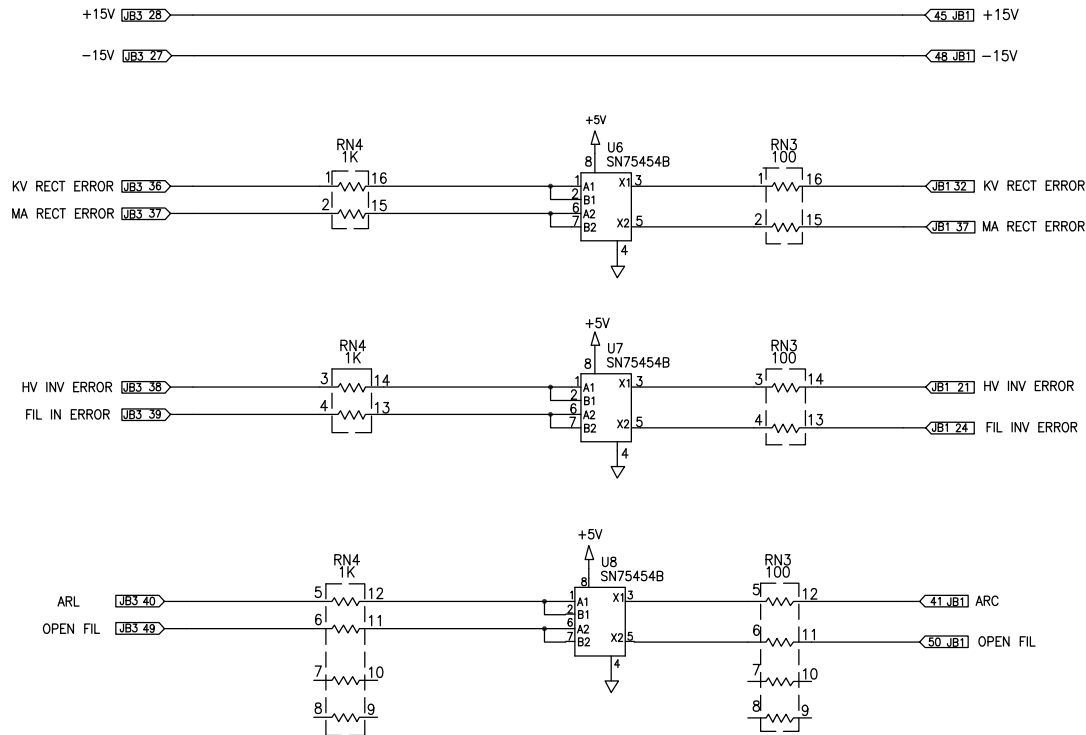

Spellman 475 Wireless Boulevard
Hauppauge, New York 11788

**SCHEMATIC DIAGRAM
INTERFACE PWB**

SIZE	CODE IDENT NO.	DRAWING NO.	REV
D	10610	440547-001	C3
SCALE: NONE	THIRD ANGLE PROJECTION	SHEET 3 OF 3	

THIS INFORMATION CONTAINED HEREIN IS PROPRIETARY TO SPELLMAN HIGH VOLTAGE ELECTRONICS CORP. AND IS TO BE USED ONLY FOR THE PURPOSES INTENDED AND IS NOT TO BE REPRODUCED EITHER IN WHOLE OR PART WITHOUT THE EXPRESS WRITTEN PERMISSION OF SPELLMAN HIGH VOLTAGE ELECTRONICS CORP.

DESCRIPTION OF HOLES
HOLE SIZES APPLY TO INSTALLATION SIDE OF HOUSING, IF APPLICABLE

SYM	DESCRIPTION	QTY

REVISIONS				APPROVED		
LTR	DESCRIPTION	DATE	DESIGN	PROJ	QUALITY	REV
B	RELEASED PER ECN 6685	2/18/93	J/A	SP	JX	J/A
C	REVISED PER ECN NO. 6882	2/24/93	J/A	SP	JX	J/A
C1	REVISED PER ECN NO. 7764	2/24/93	J/A	SP	JX	J/A
C2	REVISED PER ECN NO. 12786	10/21/94	J/A	SP	JX	J/A
C3	REVISED PER ECN NO. 16520	1/9/94	J/A	SP	JX	J/A
C4	REVISED PER ECN NO. 19682	12/9/94	J/A	SP	JX	J/A
C5	REVISED PER ECN NO. 19983	3/9/97	J/A	SP	JX	J/A

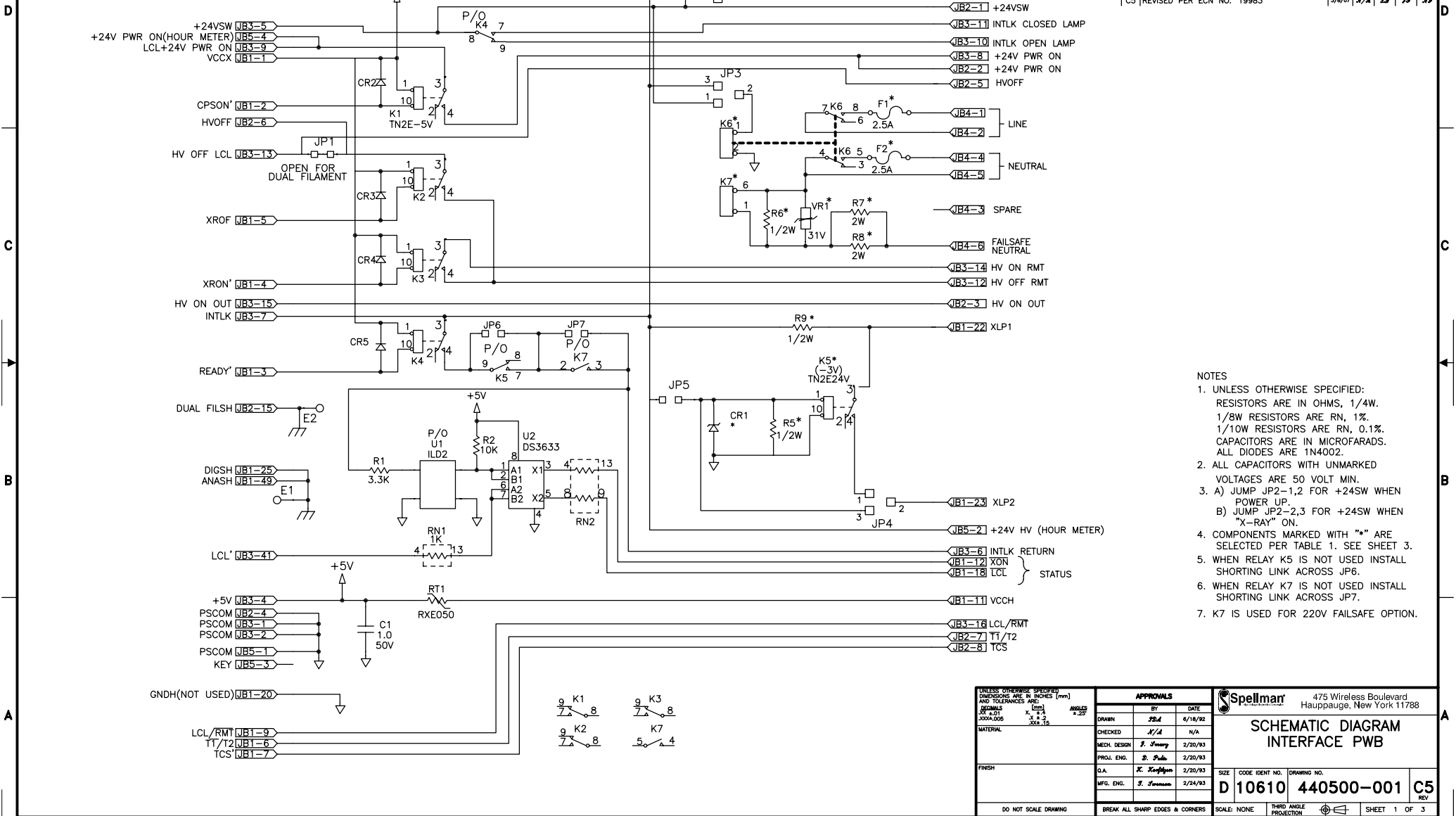

- NOTES**
- UNLESS OTHERWISE SPECIFIED: RESISTORS ARE IN OHMS, 1/4W. 1/8W RESISTORS ARE RN, 1%. 1/10W RESISTORS ARE RN, 0.1%. CAPACITORS ARE IN MICROFARADS. ALL DIODES ARE 1N4002.
 - ALL CAPACITORS WITH UNMARKED VOLTAGES ARE 50 VOLT MIN.
 - A) JUMP JP2-1,2 FOR +24SW WHEN POWER UP. B) JUMP JP2-2,3 FOR +24SW WHEN "X-RAY" ON.
 - COMPONENTS MARKED WITH "*" ARE SELECTED PER TABLE 1. SEE SHEET 3.
 - WHEN RELAY K5 IS NOT USED INSTALL SHORTING LINK ACROSS JP6.
 - WHEN RELAY K7 IS NOT USED INSTALL SHORTING LINK ACROSS JP7.
 - K7 IS USED FOR 220V FAILSAFE OPTION.

UNLESS OTHERWISE SPECIFIED AND TOLERANCES ARE IN [] (mm)		APPROVALS		Spellman		
FORMING	ANGLES	BY	DATE	475 Wireless Boulevard Hauppauge, New York 11788		
0.0125	0.25	SP	6/18/92	SCHEMATIC DIAGRAM INTERFACE PWB		
0.025	0.5	CHECKED	J/A			1/4
0.05	1.0	MECH. DESIGN	J. J. J.			2/20/93
0.1	2.0	PROJ. ENG.	S. S.			2/20/93
0.2	5.0	Q.A.	K. K.			2/20/93
0.5	12.5	MFG. ENG.	J. J.	2/24/93		
FINISH				SIZE	CODE IDENT NO.	DRAWING NO.
				D	10610	440500-001
DO NOT SCALE DRAWING				SCALE: NONE	THIRD ANGLE PROJECTION	SHEET 1 OF 3

THIS INFORMATION CONTAINED HEREIN IS PROPRIETARY TO SPELLMAN HIGH VOLTAGE ELECTRONICS CORP. AND IS TO BE USED ONLY FOR THE PURPOSES INTENDED AND IS NOT TO BE REPRODUCED EITHER IN WHOLE OR PART WITHOUT THE EXPRESS WRITTEN PERMISSION OF SPELLMAN HIGH VOLTAGE ELECTRONICS CORP.

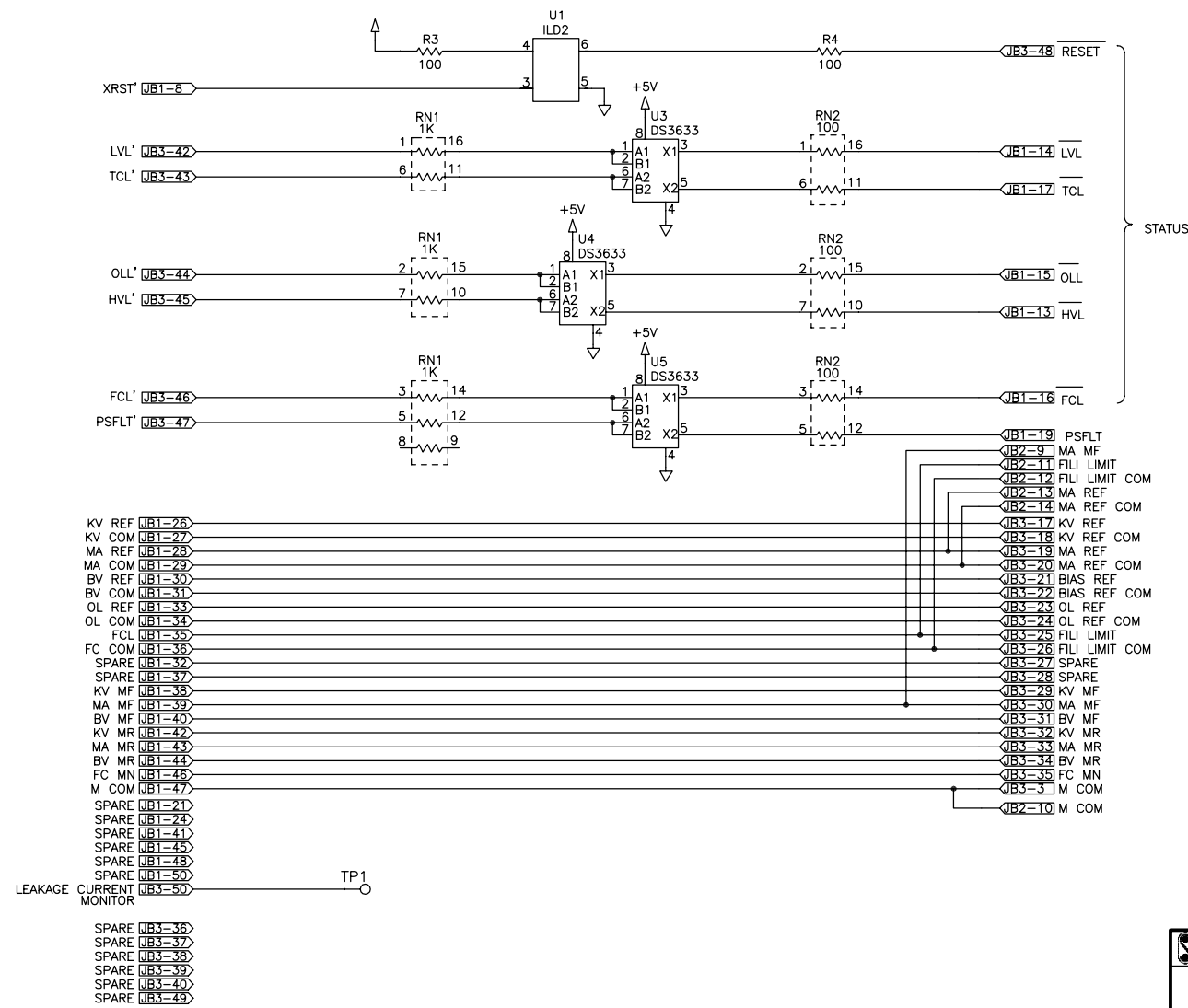

Spellman 475 Wireless Boulevard
Hauppauge, New York 11788

**SCHEMATIC DIAGRAM
INTERFACE PWB**

SIZE	CODE IDENT NO.	DRAWING NO.	REV
D	10610	440500-001	C5

SCALE: NONE THIRD ANGLE PROJECTION SHEET 2 OF 3

THIS INFORMATION CONTAINED HEREIN IS PROPRIETARY TO SPELLMAN HIGH VOLTAGE ELECTRONICS CORP. AND IS TO BE USED ONLY FOR THE PURPOSES INTENDED AND IS NOT TO BE REPRODUCED EITHER IN WHOLE OR PART WITHOUT THE EXPRESS WRITTEN PERMISSION OF SPELLMAN HIGH VOLTAGE ELECTRONICS CORP.

TABLE I

ASSY DASH NO.	APPLICATION	F1/F2	JB2	JB4	SHORTING LINKS						K5	K6	K7	R5	R6	R7/8	R9	VR1	TP1	CR1
					JP2	JP3	JP4	JP5	JP6	JP7										
450001-999	-	-	-	-	-	-	-	-	-	-	-	-	-	-	-	-	-	-	-	-
450001-001	DF3	IN	NR	IN	1-2	2-3	2-3	OUT	OUT	IN	IN/3V	IN	OPT	220	OPT	OPT	0	OPT	NR	P6KE6.8
450001-002	FF3	IN	NR	IN	1-2	2-3	2-3	OUT	OUT	IN	IN/3V	IN	OPT	220	OPT	OPT	0	OPT	IN	P6KE6.8
450001-003	X1932	IN	NR	IN	1-2	2-3	2-3	OUT	IN	IN	N/R	IN	NR	220	NR	NR	NR	NR	NR	N/R
450001-004	X1807/1996	NR	NR	NR	OUT	OUT	1-2	IN	OUT	IN	IN/24V	NR	NR	NR	NR	NR	NR	NR	NR	P6KE39
450001-005	X1919/1920	NR	IN	NR	OUT	OUT	1-2	IN	OUT	IN	IN/24V	NR	NR	NR	NR	NR	NR	NR	IN	P6KE39
OPTION	12V FSI	-	-	-	-	-	-	-	-	-	IN/12V	-	-	1K	-	-	0	-	-	-

 475 Wireless Boulevard
 Hauppauge, New York 11788
SCHEMATIC DIAGRAM
INTERFACE PWB

SIZE	CODE IDENT NO.	DRAWING NO.	
D	10610	440500-001	C5
SCALE: NONE	THIRD ANGLE PROJECTION		SHEET 3 OF 3